

RYDEEN[®]

find your road



Owner's Manual

BM354S

Stand-Alone BackUp Monitor (3.5-inch)

⚠ WARNINGS ⚠

● PROFESSIONAL INSTALLATION REQUIRED

The following instructions are intended for professional installers.

● DAMAGE FROM INSTALLATION BY NON-AUTHORIZED INSTALLERS IS NOT COVERED BY WARRANTY.

- Dropping your BM354S unit or subjecting it to excessive shock and vibrations as this may cause it to malfunction and is not covered by warranty.
- **The BM354S unit IS NOT WATERPROOF.** Avoid exposing it to rain or other forms of excessive moisture. Water damage is not covered under the warranty.

1.Specification

Model:	BM354S
Screen Size	3.5-inch TFT-LCD
Resolution	320 X 240 Pixels
Display Aspect	4:3
Color	RGB
Video System	NTSC/PAL
Brightness	350LUX
Video Input	2 Sources Input (Aux input 1, BackUp Camera Input 2)
Current Consumption	MAX: 150mA (DC12V)
Voltage Input	DC 10 – 16V
Operation Temperature	-20°C to +70°C
Storage Temperature	-30°C to +80°C

2.Wiring

RED- 12V+ Ignition

Black- Chassis Ground

BackUp Camera RCA (V2)- Video input for camera (priority) This circuit switches automatically when video is sensed by powering up the reverse camera

VIDEO IN RCA (V1)- AUX Video input (DVD, MP4 etc.) This circuit is secondary and so it will be over written when Camera video is sensed.

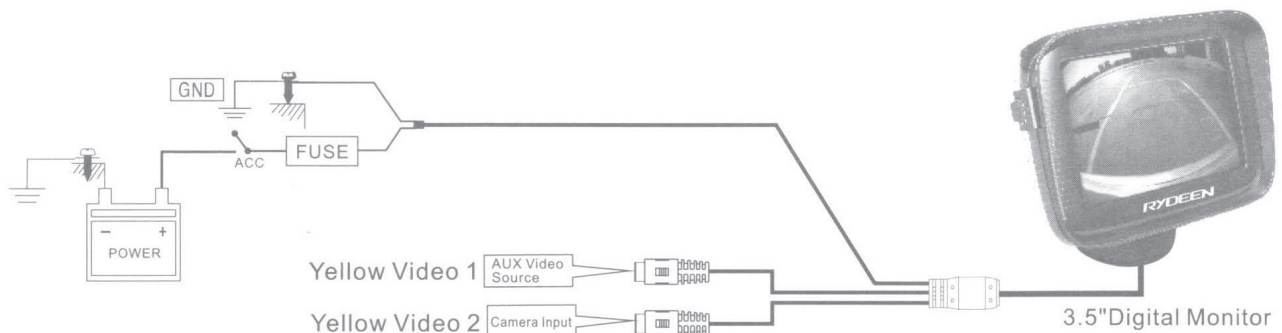

1) AUX Video Source operation is controlled by Video Source (Monitor will stay in Stand-By mode unless video source is detected).

2) Camera Input functions same as AUX but when Camera is detected it overrides AUX source.

3. Monitor Mount Positions

The monitor mount has a 360 degree rotating ball mount which allows for multiple mounting options. Most popular are Dash Board Mounting (figure 1) and Windshield Mounting (figure 2).

Note: Follow local laws when mounting monitor as their may be specific regulations in your area limiting placement.

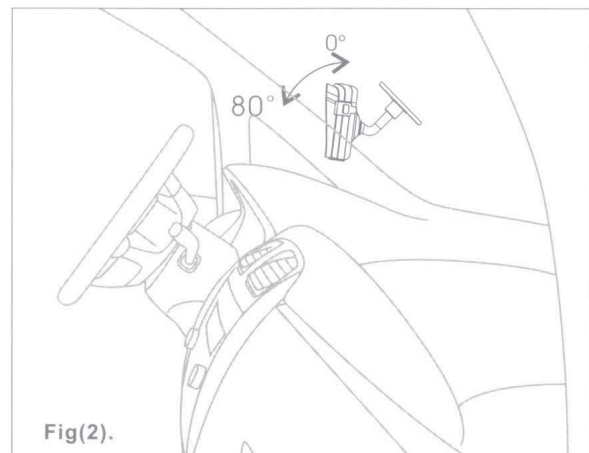
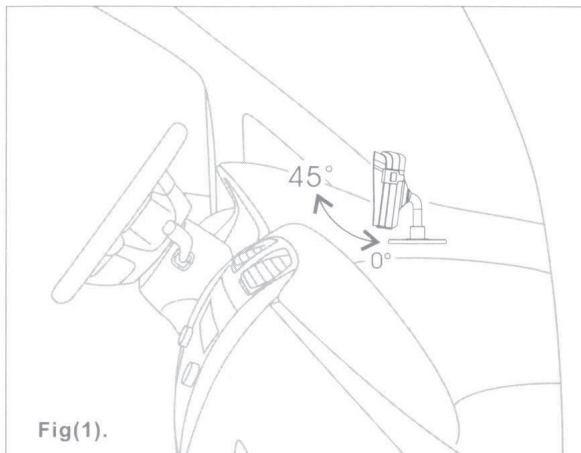

4. Setup

- 1) Turn Ignition ON
- 2) When AUX video source is connected to V1 then turn video source ON and it will automatically show the image on screen.
- 3) Shift vehicle into reverse, the camera image will appear on the screen when V2 is properly connected to a camera.
- 4) Shift vehicle out of reverse and the camera image will disappear and go back to its previous stage.

5. Button Operation

Mirror / Standard Image Button (located at the right side lower position) :
Press once to select between mirror/standard image.

6. Trouble Shooting



The Camera may be receiving too much light into the lens. This is normally due to a poorly adjusted camera which may be capturing too much direct sunlight. Adjust camera so that it does not capture too much sunlight.



The Camera may have excessive amount of dust/ dirt/ grime, using a mild detergent clean the camera lens and retest.



The Camera may not have sufficient back light for it to capture a clear image. Check to make sure that the vehicle reverse lamps are turning On when the vehicle is shifted into reverse.

One Year Limited Warranty

Rydeen North America Inc. (a manufacturer of "Rydeen" products) warrants the product only to the original purchaser as described following:

Warranty Period

Rydeen warrants this product for a period of one (1) year from the original purchase date.

Warranty Coverage

This warranty covers all defects in material and workmanship except as specified below.

1. Installation by anyone other than an authorized Rydeen Mobile Retailer voids the warranty.
2. Any products distributed outside of the USA by Rydeen North America Inc. (Rydeen) or which is not purchased in the USA or Canada unless the product is purchased through the USA Military Exchange Service.
3. Any product(s) which are purchased from an unauthorized retailer (in store or online).
4. Any products in which the serial number label or the model number label are removed, torn, modified or replicated.
5. Any damage defects or malfunctions resulting from any of following:
 - a) When defect occurs during shipment of product (freight carrier's responsibility).
 - b) Installation or removal of product.
 - c) Accidents, act of nature, misuse, abuse, neglect, unauthorized product modification or failure to follow product owner's manual instructions.
 - d) Any repair or attempt to repair without RYDEEN authorization.
 - e) Any other cause which is not related to product defect.
 - f) Any cosmetic damages due to normal wear and tear.
 - g) Any consumable items (such as fuse or batteries).

If any problems develop with your Rydeen products during or after the Limited Warranty Period, or if you have any questions regarding the operation or installation of the product, you should contact your Rydeen retailer. If the problem or your question is not handled to your satisfaction, please contact Rydeen Customer Service Department at 1-877-777-8811 (within the USA only) Monday - Friday between 9:00 AM to 4:00 PM Pacific Standard Time or visit www.rydeenmobile.com.



Rydeen North America Inc.
dba Rydeen Mobile Electronics
2701 Plaza Del AMO, Suite 705, Torrance, California 90503 USA
Phone: 1-877-777-8811 Fax: 1-310-943-3778

Copyright © 2012 Rydeen North America Inc. All Rights Reserved.

These materials are protected by copyright law and international treaties. Any unauthorized use, reproduction or distribution of these materials, or any portion herein, will result in severe civil and criminal penalties and fines. Violators will be prosecuted to the fullest extent of the law.

One Year Limited Warranty

Rydeen North America Inc. (a manufacturer of "Rydeen" products) warrants the product only to the original purchaser as described following:

Warranty Period

Rydeen warrants this product for a period of one (1) year from the original purchase date.

Warranty Coverage

This warranty covers all defects in material and workmanship except as specified below.

1. Installation by anyone other than an authorized Rydeen Mobile Retailer voids the warranty.
2. Any products distributed outside of the USA by Rydeen North America Inc. (Rydeen) or which is not purchased in the USA or Canada unless the product is purchased through the USA Military Exchange Service.
3. Any product(s) which are purchased from an unauthorized retailer (in store or online).
4. Any products in which the serial number label or the model number label are removed, torn, modified or replicated.
5. Any damage defects or malfunctions resulting from any of following:
 - a) When defect occurs during shipment of product (freight carrier's responsibility).
 - b) Installation or removal of product.
 - c) Accidents, act of nature, misuse, abuse, neglect, unauthorized product modification or failure to follow product owner's manual instructions.
 - d) Any repair or attempt to repair without RYDEEN authorization.
 - e) Any other cause which is not related to product defect.
 - f) Any cosmetic damages due to normal wear and tear.
 - g) Any consumable items (such as fuse or batteries).

If any problems develop with your Rydeen products during or after the Limited Warranty Period, or if you have any questions regarding the operation or installation of the product, you should contact your Rydeen retailer. If the problem or your question is not handled to your satisfaction, please contact Rydeen Customer Service Department at 1-877-777-8811 (within the USA only) Monday - Friday between 9:00 AM to 4:00 PM Pacific Standard Time or visit www.rydeenmobile.com.



Rydeen North America Inc,
dba Rydeen Mobile Electronics
2701 Plaza Del AMO, Suite 705, Torrance, California 90503 USA
Phone: 1-877-777-8811 Fax: 1-310-943-3778