



## **CUP SERIES DIGITAL BASS ENHANCER**



# **CUP2**

# **USERS MANUAL**



# Introduction

Congratulations on your purchase of Cerwin-Vega Mobile products for your car audio system. You have chosen Cerwin Vega Mobile because you deserve the best!

Cerwin-Vega Mobile CVP series digital bass enhancer are designed and engineered to reproduce extreme bass output in your vehicle! Our authorized Cerwin Vega Mobile dealers can help guide you with various installation applications and technical information in order to customize your sound system according to your own listening preference. It is highly recommended that you have your new digital bass enhancer installed by an authorized Cerwin Vega Mobile dealer to ensure that you receive the ultimate listening experience!

If you decide to install digital bass enhancer by yourself, please thoroughly read through this manual before getting started. This manual will help familiarize yourself with this product and guide you through the installation process and procedures for this particular product. Please contact your local authorized Cerwin-Vega Mobile dealer if you have any further questions regarding the instructions in this manual pertaining to digital bass enhancer application and installation process. If you require additional assistance, please contact the Cerwin-Vega Mobile Technical Support Department during business hours at 213-261-4161.

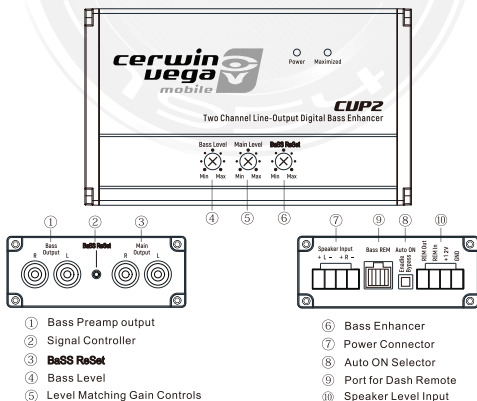

## Features

Speaker Level Input Accepts Up To 400 Watts RMS
Bass Enhancer Bass Compensation
Selectable Auto ON
9.5 Volt Pre-out
12 Volt Trigger Out
Dual Amplifier Outputs
Level Matching Controls
Dash Remote Level Control

### Setting the BaSS ReSet® Bass Compensation:

Factory speaker systems have trouble reproducing loud clean bass. Some car manufacturers limit the bass output of their systems at higher volumes so as not to damage speakers. The BaSS ReSet® circuit puts that bass back.

Here's how you set it up. After the CVP2 processor and amplifiers and speakers are installed and ready go:

1. Turn the system on and play music with a good bass track and vocals.
2. Turn the volume up while listening for the bass. Watch how far you are turning the volume control.
3. If you hear a place where the bass seems to just drop right out...stop. Leave the volume there and go to your CVP2.
4. Set the BaSS ReSet® Level control on the top of CVP2 to the center detent.

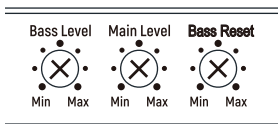

5. Now, using a small screwdriver to turn the BaSS ReSet control clockwise slowly until you hear the bass come back in.

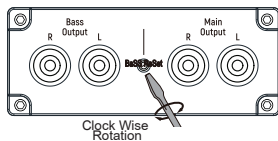

6. Re-adjust the BaSS ReSet® Level control on the top of the unit to get the proper amount of bass compensation plus Level, and you're ready for some ground pounding bass. OK, what if your bass doesn't roll off, but you still want more? No problem! Turn the BaSS ReSet Level control fully down, rotate the threshold control fully clockwise to lock in the bass equalization.

**Now you can turn up the BaSS ReSet Level control on the remote for the amount of bass you want.**

# Signal Connection

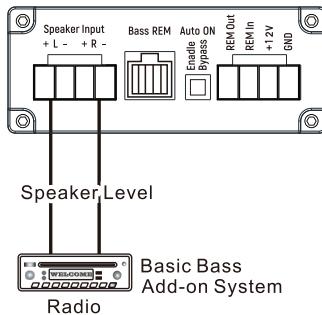
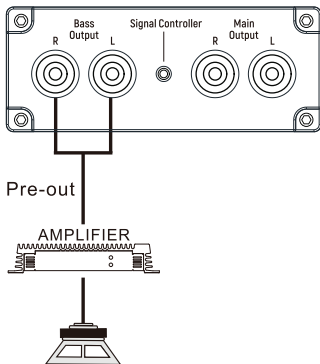

Signal Controller

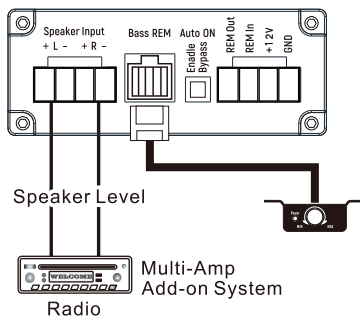
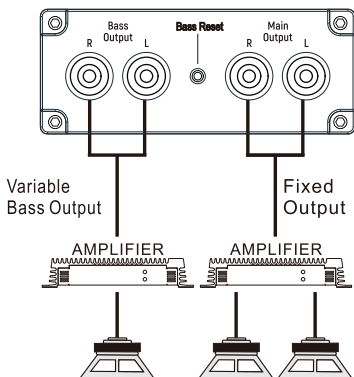

## Specifications

Maximum Speaker Level Input	400 watts per channel @4 Ohms
Maximum Preamp Output	9.5V RMS/12V PEAK
Dash Level Remote Control	+0dB / -19dB
Frequency Response	10Hz-100kHz; $\pm 1$ dB
Total Harmonic Distortion	0.01%
Signal To Noise Ratio	>11dB
Input Impedance	20K Ohms
Output Impedance	150 Ohms
Power Draw	150mA
Recommended Fuse Rating	1 Amp

# Warranty

Thank you for purchasing a Cerwin Vega Mobile product and we hope to provide you with countless hours of listening enjoyment. Please take a brief moment to register your new product. By registering your new product, you will receive benefits such as:

- Important product notifications that may pertain to your purchase.
- Confirmation and record of ownership in case of loss or theft.
- Knowledgeable customer service and technical assistance pertaining to your product.

To register your new product, please visit our website at:  
[www.cerwinvegamobile.com](http://www.cerwinvegamobile.com)

Registration is voluntary and failure to register will not diminish your limited warranty rights.

## Limited Warranty (U.S.A.)

Cerwin Vega Mobile warrants all of our amplifiers and speakers to be free of defects in materials and workmanship for a period of one (1) year.

This warranty is non-transferable and applies only to the original purchaser from an authorized Cerwin Vega Mobile dealer. If service is required and necessary under this warranty due to manufacturing defect or malfunction, then Cerwin Vega Mobile will repair and/or replace defective product with either new or remanufactured like product at no charge at our discretion.

Damage to product caused by the following will not be covered under this warranty: abuse, accident, misuse, neglect, modifications, repairing attempts, seller/installer misrepresentation.

This warranty does not cover any incidental, consequential, or cosmetic damage due to accidents or normal wear and tear, nor does it cover the cost of removing or reinstallation of the product.

Warranty is void if the product's serial number has been removed, defaced, and/or tampered with.

## Warranty Procedure:

We recommend that you contact your Cerwin Vega Mobile authorized dealer where your original purchase was made to initiate all warranty claims. Our authorized dealers can guide you through the warranty procedure to ensure that your claim will be processed in a timely manner. All warranty returns must be accompanied with a proof of purchase (a copy of the original sales receipt) and be shipped freight prepaid to our facility with an RA (Return Authorization) number clearly marked on the outside of the package. Direct returns from consumers or non-authorized dealers will be refused if shipped without a valid RA number authorized by Cerwin Vega Mobile beforehand.

For subwoofer returns, remove the cone from the basket by cutting the surround and then the spider, thus allowing the cone to completely lift out. All returns must have the serial numbers taped to the cone. The serial number can be found on the basket of all speakers and underneath the spider attached to the top of the magnet plate. Please remove the sticker and tape it to the cone.

For coaxial speaker returns, the tweeter should be broken off and sent in with the cone. For component speakers, only return the defective part such as tweeter, midbass, or crossover only.

Products purchased in countries outside the U.S.A. are warranted by the CVM authorized country distributor in which the product was purchased, go to [www.cerwinvegamobile.com](http://www.cerwinvegamobile.com) to find contact information for warranty within your country.

## Please Ship All Warranty Claims With Pre-Authorized RA Number To:

CV&DA Holdings, Inc.  
ATTN: Customer Service Department  
3761 South Hill St  
Los Angeles, CA 90007 USA

## Please Contact Customer Service for Further Warranty Information:

U.S.A.  
Tel: 213-261-4167 Hours: 8:30 AM – 5:30 PM (Pacific Standard Time)  
INTERNATIONAL

Products purchased outside of the U.S.A. are covered only by that country's distributor and not by Cerwin Vega Mobile U.S.A.

## AMPLIFIER GAIN SETTINGS:

**NOTE:** Use this page to make notes on where gains settings are and Bass level and BaSSReSet are. So in the future if anything comes up, you can resolve quickly.

FRONT



REAR



SUB



NOTES:

---

---

---

---

---

---

---

---



**3761 South Hill Street  
Los Angeles 90007, USA  
P 213-261-4161 / F 213-947-4767**

**MAKING IT LOUD SINCE 1954!**

**⚠ California Prop 65 Warning ⚠**

**WARNING:** This product can expose you to chemicals, including DEHP compounds which are known to the State of California...to cause cancer, and birth defects or other reproductive harm.

*For more information, please visit:  
[www.P65Warnings.ca.gov](http://www.P65Warnings.ca.gov)*

**WWW.CERWINVEGAMOBILE.COM**

**2019 Cerwin Vega Mobile All rights reserved.  
(a division of CV & DA Holdings, Inc.)**