

Source Unit

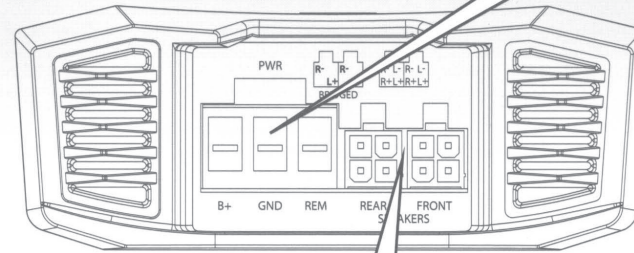

Switched 12V to REM
(NOT Required if using high level inputs.
Refer to manual for more information.)

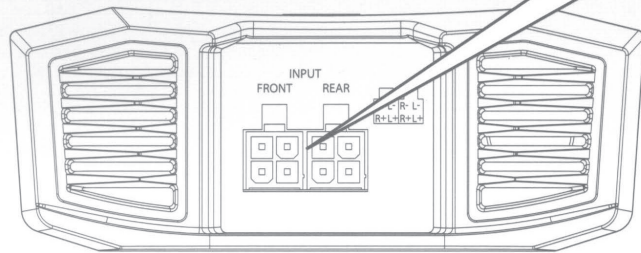
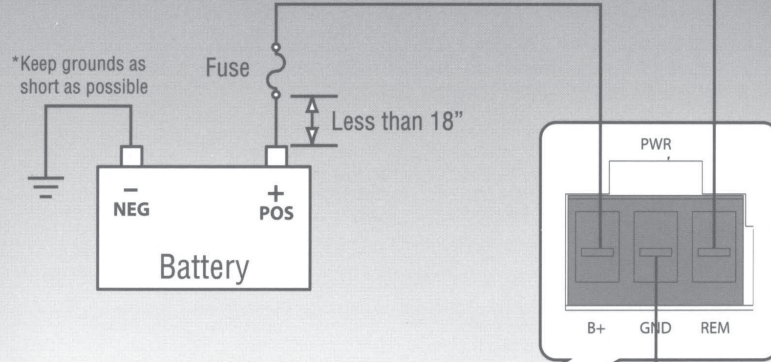
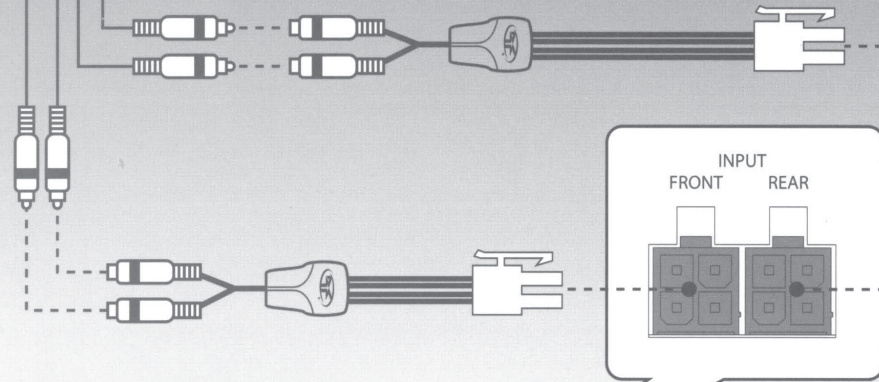

Connect to chassis ground of vehicle

*Keep grounds as short as possible. For Motorsport and Boat applications, the ground wire should go directly to the negative battery terminal.

Optional Accessory
PLC2 (T400X2ad/T500X1bd)

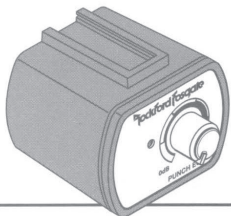

CAUTION
Be sure to connect speakers and Punch Level Control - PLC (if equipped) after amplifier output clip adjustment. (see reverse)

* Specifications subject to change without notice. Images depict typical setup. Refer to manual for additional wiring options.

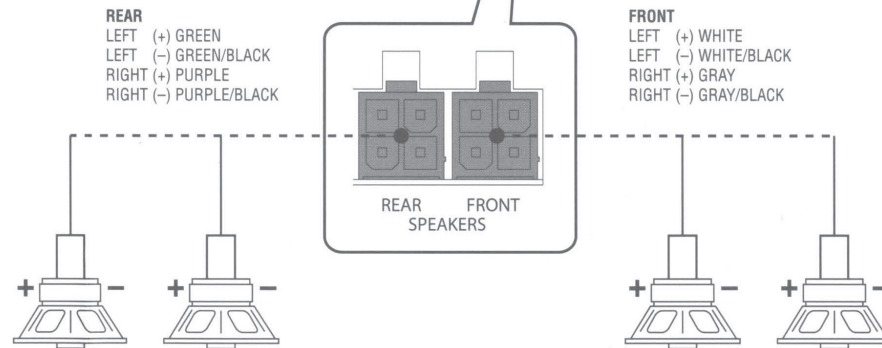

WIRE HARNESS COLOR CODE

Step 1 - Input

Input Clip Indicator Setup

Be sure to disconnect all speakers from the amplifier.

CAUTION

Failure to comply may cause damage to connected components and/or amplifier.

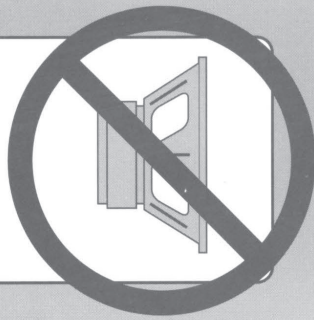

Step 2 - Input

Turn on the source unit with volume set to zero.

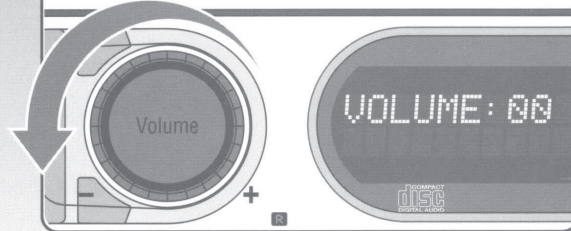

Step 3 - Input

Adjust the Bass & Treble levels on the source unit to flat.



Step 4 - Input

Insert test tone or music CD to play for setup.



Note: Use the 40Hz @ 0dB tone (Track 5) for mono amplifier applications or the 1kHz @ 0dB tone (Track 7) for multi-channel amplifier applications. Be sure your x-over is switched to the appropriate filter setting.

Step 5 - Input

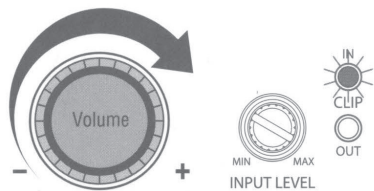

Increase the source unit volume until the Input Clip Indicator illuminates red.

Note: Input Clip can be viewed remotely with optional PLC2.

Step 6 - Input

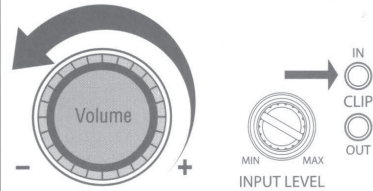

Decrease the source unit volume slightly until the light turns completely off. This establishes your maximum source unit volume for adjusting the Output Clip Indicator.

Note: Some source units will not clip.

Step 7 - Output

Be sure to disconnect Punch Level Control - PLC (if equipped) from the amplifier.

Step 8 - Output
Output Clip Indicator Setup

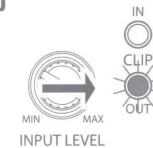

Adjust the Input Level knob until the Output Clip Indicator illuminates to the appropriate color. Repeat for all channel levels of input.

Step 9 - Output

Turn the source unit volume down.

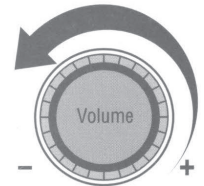

Step 10 - Output

Reconnect all speakers and Punch Level Control - PLC (if equipped) to the amplifier. Be sure to maintain proper speaker polarity.

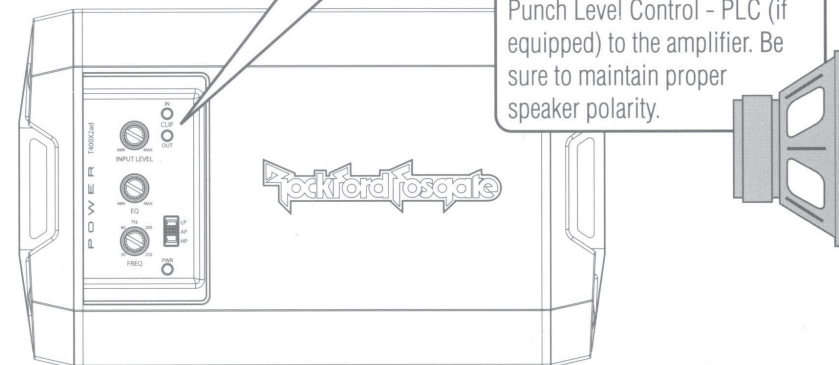
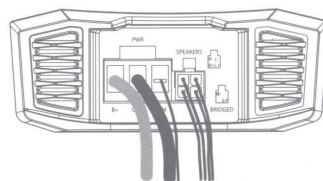
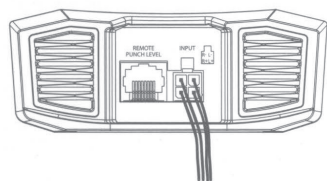

P O W E R



T400X2ad • T400X4ad
T500X1br

Dear Customer,

Congratulations on your purchase of the world's finest brand of car audio products. At Rockford Fosgate we are fanatics about musical reproduction at its best, and we are pleased you chose our product. Through years of engineering expertise, hand craftsmanship and critical testing procedures, we have created a wide range of products that reproduce music with all the clarity and richness you deserve.

For maximum performance we recommend you have your new Rockford Fosgate product installed by an Authorized Rockford Fosgate Dealer, as we provide specialized training through Rockford Technical Training Institute (RTTI). Please read your warranty and retain your receipt and original carton for possible future use.

Great product and competent installations are only a piece of the puzzle when it comes to your system. Make sure that your installer is using 100% authentic installation accessories from Rockford Fosgate in your installation. Rockford Fosgate has everything from RCA cables and speaker wire to power wire and battery connectors. Insist on it! After all, your new system deserves nothing but the best.

To add the finishing touch to your new Rockford Fosgate image order your Rockford accessories, which include everything from T-shirts to jackets.

Visit our web site for the latest information on all Rockford products; www.rockfordfosgate.com or, in the U.S. call 1-800-669-9899 or FAX 1-800-398-3985. For all other countries, call +001-480-967-3565 or FAX +001-480-966-3983.

Table of Content

- 2 Introduction
- 3 Specifications
- 4-5 Design Features
- 6-13 Installation
 - Installation Considerations
 - Mounting Locations
 - Battery and Charging
 - Wiring the System
- 14-15 Operation
 - Clip Indicator Setup
 - Adjusting Crossover Frequency
 - 2/4 Channel Switch
 - Punch EQ
- 16 Troubleshooting
- 17 Limited Warranty Information

If, after reading your manual, you still have questions regarding this product, we recommend that you see your Rockford Fosgate dealer. If you need further assistance, you can call us direct at **1-800-669-9899**. Be sure to have your serial number, model number and date of purchase available when you call.

PRACTICE SAFE SOUND

Continuous exposure to sound pressure levels over 100dB may cause permanent hearing loss. High powered auto sound systems may produce sound pressure levels well over 130dB. Use common sense and practice safe sound.

Safety

This symbol with "WARNING" is intended to alert the user to the presence of important instructions. Failure to heed the instructions will result in severe injury or death.



WARNING

This symbol with "CAUTION" is intended to alert the user to the presence of important instructions. Failure to heed the instructions can result in injury or unit damage.



CAUTION

- To prevent injury and damage to the unit, please read and follow the instructions in this manual. We want you to enjoy this system, not get a headache.
- If you feel unsure about installing this system yourself, have it installed by a qualified Rockford Fosgate technician.
- Before installation, disconnect the battery negative (-) terminal to prevent damage to the unit, fire and/or possible injury.

Mode	T400X2ad	T400X4ad	T500X1br
Rated Power - Continuous Power Rating (RMS) Measured @ 14.4V	200x2 @ 4 ohm 200x2 @ 2 ohm 400x1 @ 4 ohm*	100x4 @ 4 ohm 100x4 @ 2 ohm 200x2 @ 4 ohm*	175x1 @ 4 ohm 300x1 @ 2 ohm 500x1 @ 1 ohm
Crossover Slope	12 dB/Oct	12 dB/Oct	12 dB/Oct
Crossover Frequency	Variable 50Hz-250Hz	Variable 50Hz-250Hz	Variable 50Hz-250Hz,
Punch EQ	Variable 0 -14dB @ 12.5kHz and 0-18dB @ 45Hz	Variable 0 -14dB @ 12.5kHz and 0-18dB @ 45Hz	Variable 0-18dB @ 45Hz
Operating Voltage	9-16VDC	9-16VDC	9-16VDC
Frequency Response	20Hz-20kHz	20Hz-20kHz	20Hz-250Hz
Battery Fuse Rating (not supplied)	60A	60A	60A
THD+N @ Rated Power	<1.0% @ 4 ohm <1.0% @ 2 ohm	<1.0% @ 4 ohm <1.0% @ 2 ohm	<1.0% @ 4 ohm <1.0% @ 2 ohm <1.0% @ 1 ohm
Input Sensitivity	150mV-12V	150mV-12V	Low 150mV-5V High 300mV-12V
Input Impedance	20k	20k	20k
S/N Ratio CEA 2006	>90dB	>90dB	>90dB
S/N Ratio @ Rated Power	>110dB	>110dB	>110dB
Channel Separation	>60dB	>60dB	N/A
Common Mode Rejection Ratio	>60dB	>60dB	>60dB
Dimensions (LxWxH)	7" x 4.3" x 1.6" (17.8cm x 10.8cm x 4.1 cm)	8.3" x 4.3" x 1.6" (21.1cm x 10.8cm x 4.1 cm)	8.3" x 4.3" x 1.6" (21.1cm x 10.8cm x 4.1 cm)

* Rated power when amplifier is wired in a bridged configuration.



CEA 2006

Power ratings on Rockford Fosgate amplifiers conform to CEA-2006 industry standards. These guidelines mean your amplifier's output power ratings are REAL POWER numbers, not inflated marketing ratings.

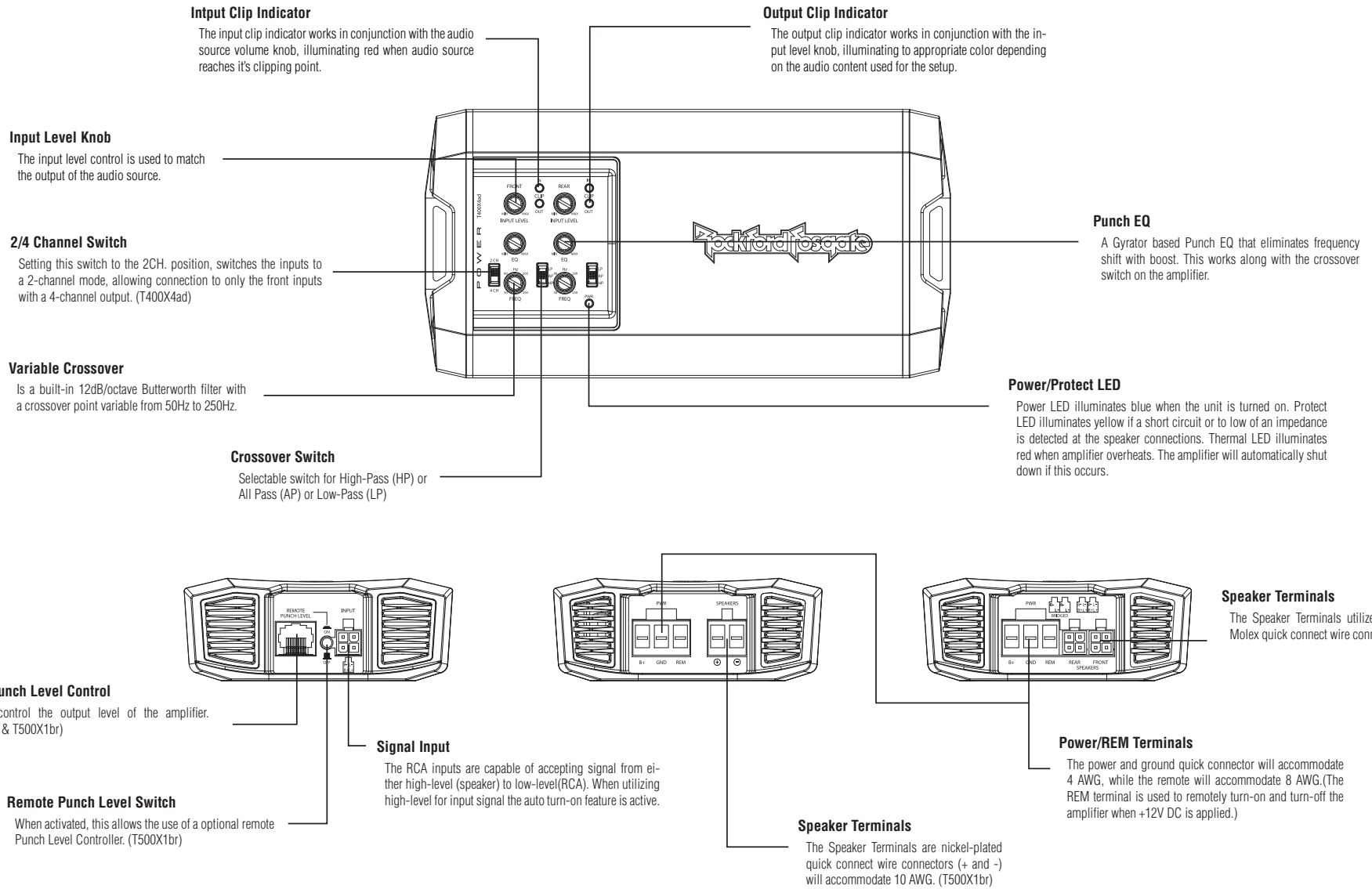

Contents

- Power Amplifier
- RCA to 4-pin Molex Input Connector(s)
- 16 AWG 4-pin Molex Speaker Connector(s) - (T400X2ad & T4004ad)
- 10 AWG Speaker Connector (T500X1br)
- Power Connector
- Quick Setup Guide
- Installation & Operation Manual
- Operation CD- (Test Tones & Installation Manual)

Installation Considerations

The following is a list of tools needed for installation:

- Fuse-holder and fuse. (See specifications for fuse rating)
- Hand held drill w/assorted bits
- Assorted connectors
- Volt/Ohm Meter
- Adequate Length—Red Power Wire
- Wire strippers
- Adequate Length—Remote Turn-on Wire
- Wire crimpers
- Adequate Length—Black Grounding Wire
- Wire cutters
- #2 Phillips screwdriver
- Battery post wrench

This section focuses on some of the vehicle considerations for installing your new amplifier. Pre-planning your system layout and best wiring routes will save installation time. When deciding on the layout of your new system, be sure that each component will be easily accessible for making adjustments.

CAUTION If you feel unsure about installing this system yourself, have it installed by a qualified technician.

CAUTION Before installation, disconnect the battery negative (-) terminal to prevent damage to the unit, fire and/or possible injury.

Before beginning any installation, follow these simple rules:

1. Be sure to carefully read and understand the instructions before attempting to install the unit.
2. For safety, disconnect the negative lead from the battery prior to beginning the installation.
3. For easier assembly, we suggest you run all wires prior to mounting your unit in place.
4. Route all of the RCA cables close together and away from any high current wires.
5. Use high quality connectors for a reliable installation and to minimize signal or power loss.

6. Think before you drill! Be careful not to cut or drill into gas tanks, fuel lines, brake or hydraulic lines, vacuum lines or electrical wiring when working on any vehicle.
7. Never run wires underneath the vehicle. Running the wires inside the vehicle provides the best protection.
8. Avoid running wires over or through sharp edges. Use rubber or plastic grommets to protect any wires routed through metal, especially the firewall.
9. ALWAYS protect the battery and electrical system from damage with proper fusing. Install the appropriate fuse holder and fuse on the +12V power wire within 18" (45.7 cm) of the battery terminal.
10. When grounding to the chassis of the vehicle, scrape all paint from the metal to ensure a good, clean ground connection. Grounding connections should be as short as possible and always be connected to metal that is welded to the main body, or chassis, of the vehicle. Seatbelt bolts should never be used for connecting to ground.

Mounting Locations

To ensure optimal performance, mount the amplifier with at least 1" (2.54cm) of air gap around the amplifier's heat sink to provide proper cooling.

Trunk Mounting

Mounting the amplifier vertically or inverted will provide adequate cooling of the amplifier. Mounting the amplifier on the floor of the trunk will provide the best cooling of the amplifier.

Passenger Compartment Mounting

Mounting the amplifier in the passenger compartment will work as long as you provide a sufficient amount of air for the amplifier to cool itself. If you are going to mount the amplifier under the seat of the vehicle, you must have at least 1" (2.54cm) of air gap around the amplifier's heat sink.

CAUTION Never mount this unit in the engine compartment. Mounting the unit in the engine compartment will void your warranty.

ATVs, Golf Carts or Motorcycle

When using amplifiers on ATVs, Golf Carts or Motorcycles, Rockford Fosgate recommends to run both GND (negative) and B+ (positive) cables from the amplifier directly to the battery. We have determined that bushings between frame parts cause an excessively high resistance and is not considered a good electrical ground.

WARNING This is especially true with motorcycles. DO NOT ground the amplifier to the radio chassis, headlamp or forks because the difference in ground potential may cause unstable operation.

CAUTION Be sure all ground connections are properly terminated for optimum electrical continuity.

Battery and Charging

Amplifiers will put an increased load on the vehicle's battery and charging system. We recommend checking your alternator and battery condition to ensure that the electrical system has enough capacity to handle the increased load of your stereo system. Stock electrical systems which are in good condition should be able to handle the extra load of any Prime Series amplifier without problems, although battery and alternator life can be reduced slightly. To maximize the performance of your amplifier, we suggest the use of a heavy duty battery and an energy storage capacitor.

Wiring the System

CAUTION If you do not feel comfortable with wiring your new unit, please see your local Authorized Rockford Fosgate Dealer for installation.

CAUTION Before installation, disconnect the battery negative (-) terminal to prevent damage to the unit, fire and/or possible injury.

CAUTION Avoid running power wires near the low level input cables, antenna, power leads, sensitive equipment or harnesses. The power wires carry substantial current and could induce noise into the audio system.

1. Plan the wire routing. Keep RCA cables close together but isolated from the amplifier's power cables and any high power auto accessories, especially electric motors. This is done to prevent coupling the noise from radiated electrical fields into the audio signal. When feeding the wires through the firewall or any metal barrier, protect them with plastic or rubber grommets to prevent short circuits. Leave the wires long at this point to adjust for a precise fit at a later time.

2. Prepare the RED wire (power cable) for attachment to the amplifier by stripping 1/2" of insulation from the end of the wire. Insert the bared wire into the B+ terminal and tighten the set screw to secure the cable in place.

NOTE: The B+ cable MUST be fused 18" or less from the vehicle's battery. Install the fuse holder under the hood and ensure connections are water tight.

3. Trim the RED wire (power cable) within 18" of the battery and splice in a inline fuse holder (not supplied). See Specifications for the rating of the fuse to be used. DO NOT install the fuse at this time.

4. Strip 1/2" from the battery end of the power cable and crimp an appropriate size ring terminal to the cable. Use the ring terminal to connect to the battery positive terminal.

5. Prepare the BLACK wire (Ground cable) for attachment to the amplifier by stripping 1/2" of insulation from the end of the wire. Insert the bare wire into the GROUND terminal and tighten the set screw to secure the cable in place. Prepare the chassis ground by scraping any paint from the metal surface and thoroughly clean the area of all dirt and grease. Strip the other end of the wire and attach a ring connector. Fasten the cable to the chassis using a non-anodized screw and a star washer.

NOTE: Keep the length of the BLACK wire (Ground) as short as possible. Always less than 30".

6. Prepare the Remote turn-on wire for attachment to the amplifier by stripping 1/2" of insulation from the end of the wire. Insert the bared wire into the REMOTE terminal and tighten the set screw to secure the wire in place. Connect the other end of the Remote wire to a switched 12 volt positive source. The switched voltage is usually taken from the source unit's remote amp on lead. If the source unit does not have this output available, the recommended solution is to wire a mechanical switch in line with a 12 volt source to activate the amplifier.

NOTE: When utilizing high-level for input signal the auto turn-on feature is active. With the auto turn-on active, the REM becomes an output to turn on/off up to two additional amplifiers or other accessories.

7. Securely mount the amplifier to the vehicle or amp rack. Be careful not to mount the amplifier on cardboard or plastic panels. Doing so may enable the screws to pull out from the panel due to road vibration or sudden vehicle stops.

8. Connect from source signal by plugging into the RCA input jacks at the amplifier. The input sensitivity ranges from 150mV-12V to accommodate signal from either high-level(speaker) to low-level (RCA).

NOTE: All "ACTIVE" inputs must have quick connectors connected. Switch in 2CH. position, "ACTIVE" - Front channel inputs only. Switch in 4CH. position, "ACTIVE" - All Front and Rear channel inputs. Be sure to route front and rear RCA cables tightly together.

CAUTION Always ensure power is off or disconnected at the amplifier before connecting input cables. Failure to do so may cause damage to the amplifier and/or connected components.

9. Connect the speakers. Strip the speaker wires 1/2" and insert into the speaker terminal and tighten the set screw to secure into place. Be sure to maintain proper speaker polarity. DO NOT chassis ground any of the speaker leads as unstable operation may result.

10. Perform a final check of the completed system wiring to ensure that all connections are accurate. Check all power and ground connections for frayed wires and loose connections which could cause problems. Install inline fuse near battery connection.

NOTE: Follow the diagrams for proper signal polarity.

CAUTION This amplifier is not recommended for impedance loads below 2-Ohm stereo/4-Ohm bridged for the multi-channel amplifiers and 1-ohm for mono amplifiers.

2-Channel (Stereo)
T400X2ad

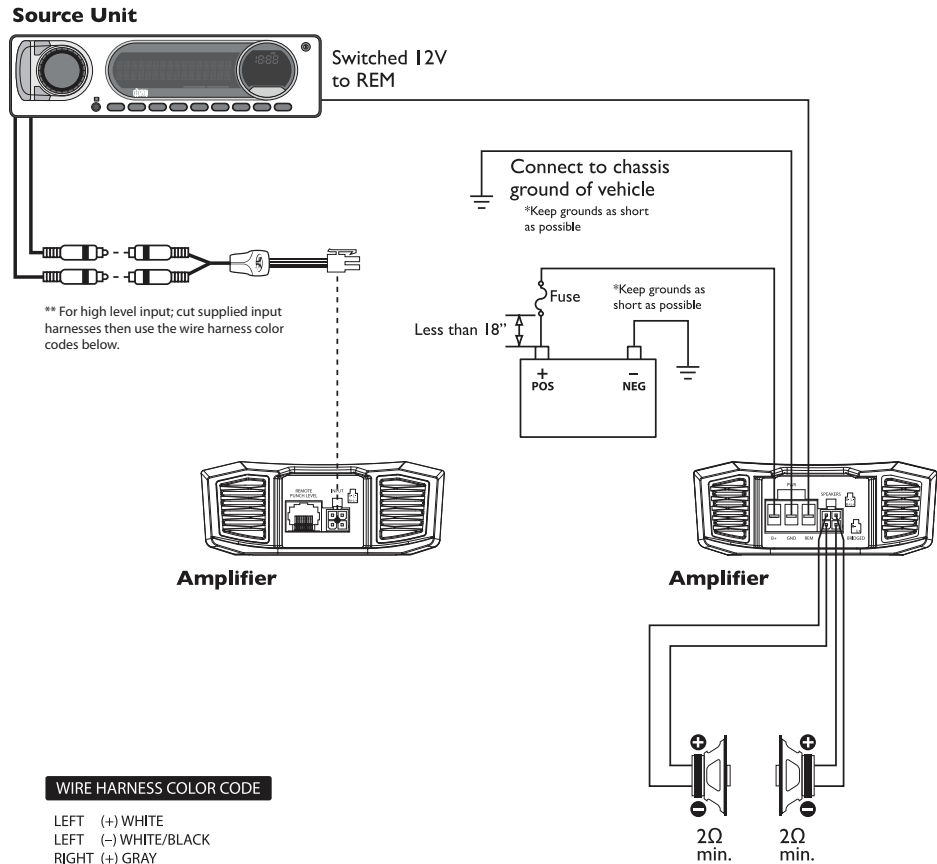

⚠ WARNING
ATVs, Golf Carts or Motorcycle
When using amplifiers on ATVs, Golf Carts or Motorcycles, Rockford Fosgate recommends to run both GND (negative) and B+ (positive) cables from the amplifier directly to the battery.

2-Channel (Mono)
T400X2ad

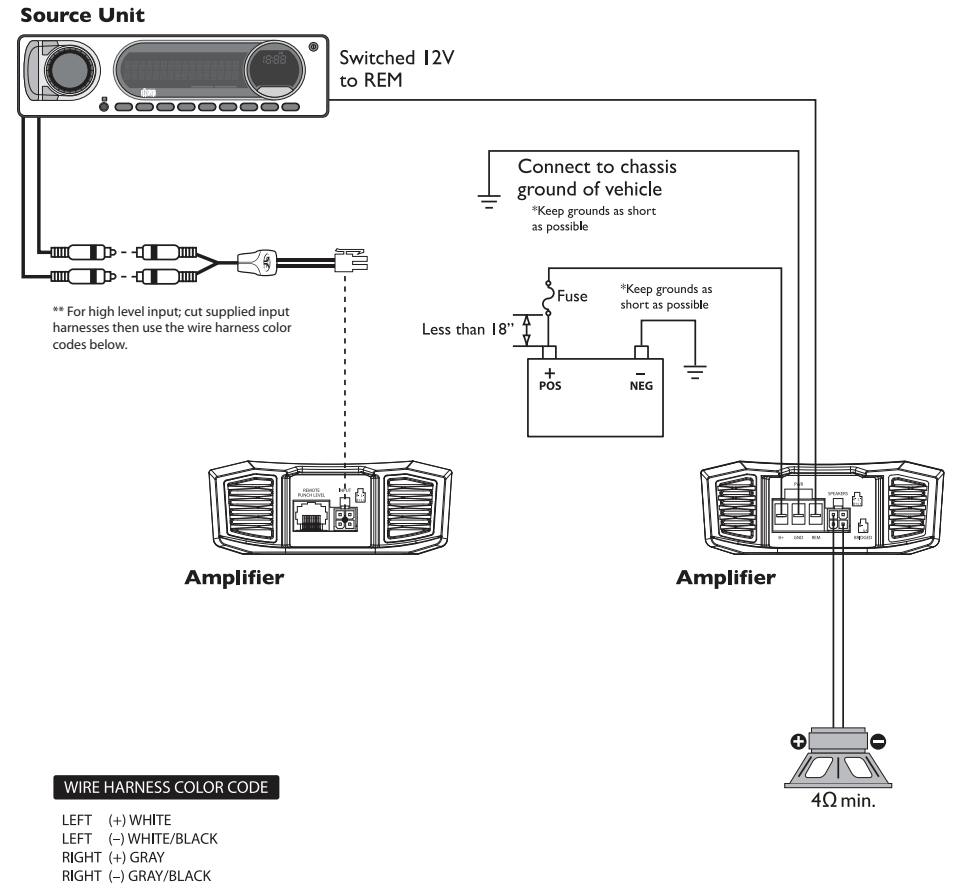

⚠ WARNING
ATVs, Golf Carts or Motorcycle
When using amplifiers on ATVs, Golf Carts or Motorcycles, Rockford Fosgate recommends to run both GND (negative) and B+ (positive) cables from the amplifier directly to the battery.

4-Channel (Stereo)
T400X4ad

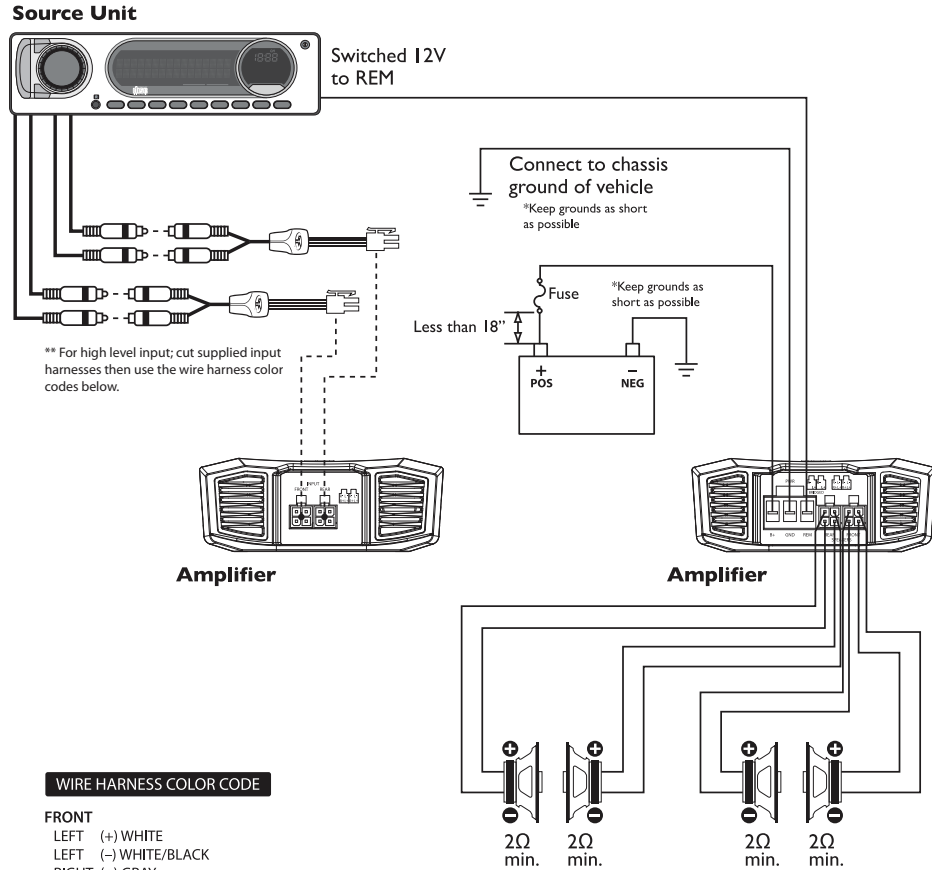

WIRE HARNESS COLOR CODE

- FRONT**
LEFT (+) WHITE
LEFT (-) WHITE/BLACK
RIGHT (+) GRAY
RIGHT (-) GRAY/BLACK
- REAR**
LEFT (+) GREEN
LEFT (-) GREEN/BLACK
RIGHT (+) PURPLE
RIGHT (-) PURPLE/BLACK

⚠ WARNING

ATVs, Golf Carts or Motorcycle

When using amplifiers on ATVs, Golf Carts or Motorcycles, Rockford Fosgate recommends to run both GND (negative) and B+ (positive) cables from the amplifier directly to the battery.

4-Channel (2ch Stereo & 1ch Mono-Bridged)
T400X4ad

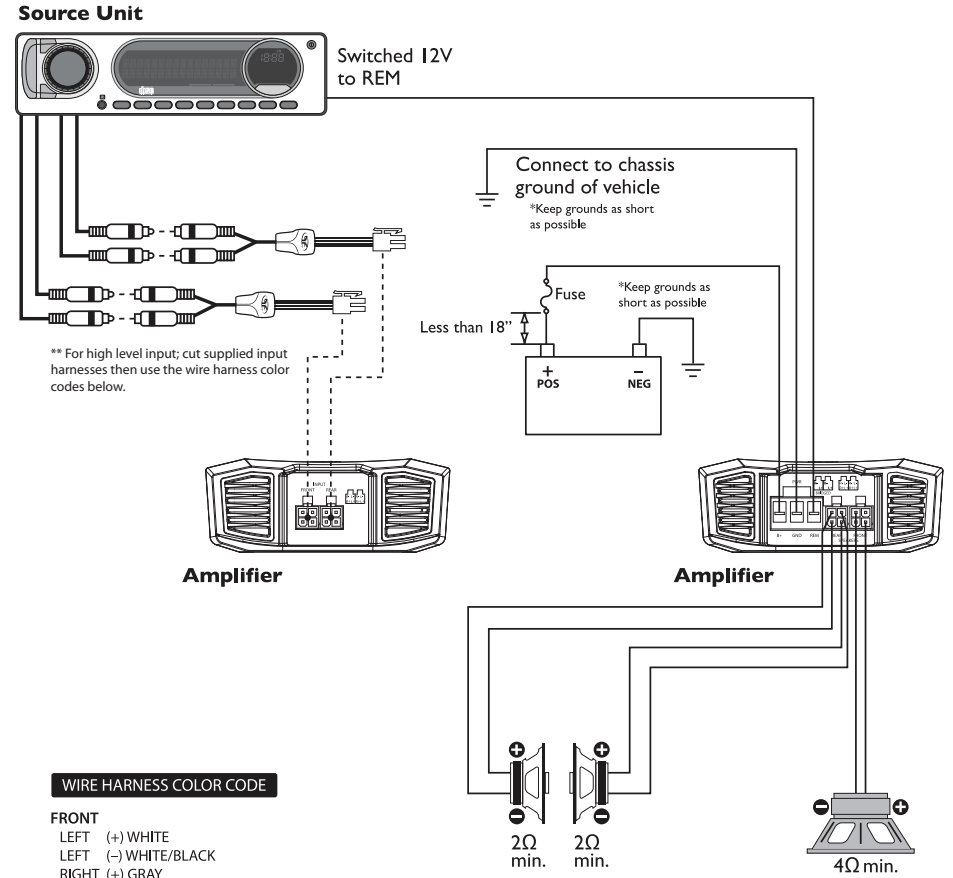

WIRE HARNESS COLOR CODE

- FRONT**
LEFT (+) WHITE
LEFT (-) WHITE/BLACK
RIGHT (+) GRAY
RIGHT (-) GRAY/BLACK
- REAR**
LEFT (+) GREEN
LEFT (-) GREEN/BLACK
RIGHT (+) PURPLE
RIGHT (-) PURPLE/BLACK

⚠ WARNING

ATVs, Golf Carts or Motorcycle

When using amplifiers on ATVs, Golf Carts or Motorcycles, Rockford Fosgate recommends to run both GND (negative) and B+ (positive) cables from the amplifier directly to the battery.

4-Channel (2ch Mono-Bridged)
T400X4ad

Source Unit

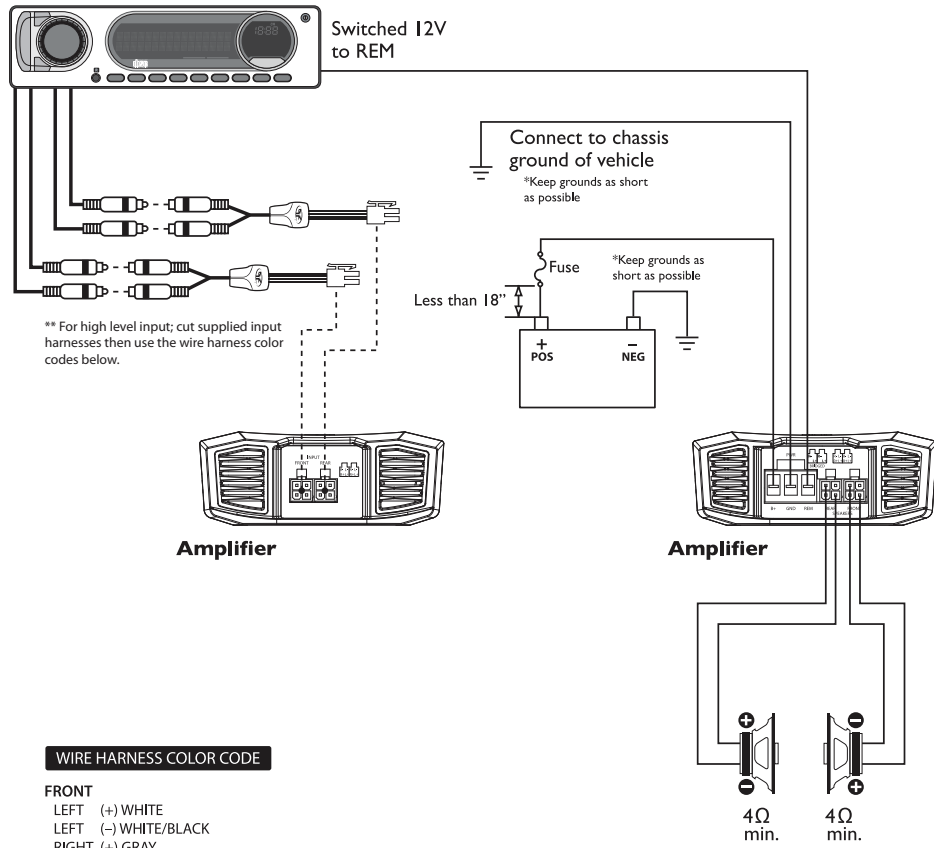

WIRE HARNESS COLOR CODE

- FRONT**
 LEFT (+) WHITE
 LEFT (-) WHITE/BLACK
 RIGHT (+) GRAY
 RIGHT (-) GRAY/BLACK
REAR
 LEFT (+) GREEN
 LEFT (-) GREEN/BLACK
 RIGHT (+) PURPLE
 RIGHT (-) PURPLE/BLACK

⚠ WARNING
ATVs, Golf Carts or Motorcycle
 When using amplifiers on ATVs, Golf Carts or Motorcycles, Rockford Fosgate recommends to run both GND (negative) and B+ (positive) cables from the amplifier directly to the battery.

Mono Wiring
T500X1br

Source Unit

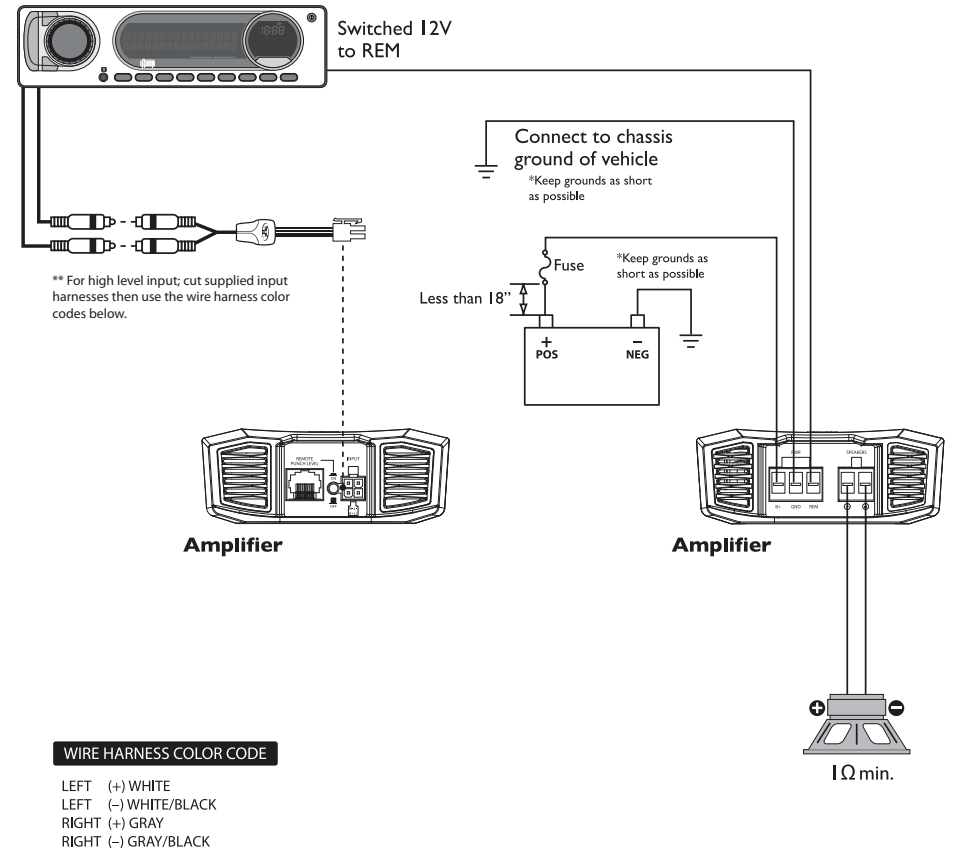

WIRE HARNESS COLOR CODE

- LEFT (+) WHITE
 LEFT (-) WHITE/BLACK
 RIGHT (+) GRAY
 RIGHT (-) GRAY/BLACK

⚠ WARNING
ATVs, Golf Carts or Motorcycle
 When using amplifiers on ATVs, Golf Carts or Motorcycles, Rockford Fosgate recommends to run both GND (negative) and B+ (positive) cables from the amplifier directly to the battery.

Input Clip Indicator Setup

Step 1. Be sure to disconnect all speakers from the amplifier.



CAUTION Failure to comply may cause damage to connected components and/or amplifier.

Step 2. Turn on the source unit with volume set to zero.

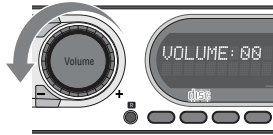

Step 3. Adjust the Bass & Treble levels on the source unit to flat.

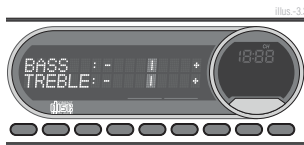

Step 4. Insert test tone or music CD to play for setup.



Note: Use the 40Hz @ 0dB tone (Track 5) for mono amplifier applications or the 1kHz @ 0dB tone (Track 7) for multi-channel amplifier applications. Be sure your x-over is switched to the appropriate filter setting.

Step 5. Increase the source unit volume until the Input Clip Indicator illuminates red.

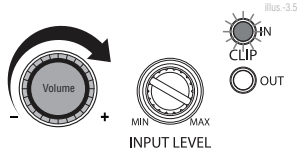

Note: Input Clip can be viewed remotely with optional PLC2.

Step 6. Decrease the source unit volume slightly until the light turns completely off. This establishes your maximum source unit volume for adjusting the Output Clip Indicator.

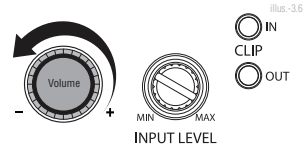

Note: Some source units will not clip.

Output Clip Indicator Setup

Step 7. Be sure to disconnect Punch Level Control - PLC (if equipped) from the amplifier.

Step 8. Adjust the Input Level knob until the Output Clip Indicator illuminates to the appropriate color. Repeat for all channel levels of input.

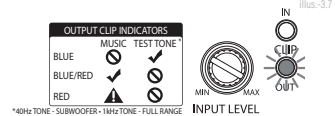

Step 9. Turn the source unit volume down.

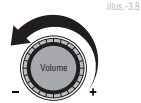

Step 10. Reconnect all speakers and Punch Level Control - PLC (if equipped) to the amplifier. Be sure to maintain proper speaker polarity.



Adjusting Crossover Frequency

Do the following individually for each channel.

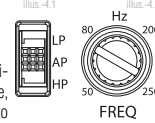

Placing the crossover switch in the HP position sets the amplifier to the High Pass mode, enabling frequencies above the cut-off point to pass, adjustable between 50-250Hz.

Placing the crossover switch in the AP position sets the amplifier to the All Pass mode, preventing any crossover adjustment, allowing all frequencies to pass.

Placing the crossover switch in the LP position sets the amplifier to the Low Pass mode, enabling frequencies below the cut-off point to pass, adjustable between 50-250Hz.

Turn the crossover adjustment knob all the way down. With the system playing, turn the crossover adjustment knob up slowly until the desired crossover point is achieved.

2/4 Channel Switch

Setting this switch to the 2CH. position, switches the inputs to a 2-channel mode, allowing connection to only the front inputs with a 4-channel output.

Output controls function the same as if the amplifier was in 4-channel mode.

All "ACTIVE" inputs must have RCA jacks connected. Switch in 2CH. position, "ACTIVE" - Front channel inputs only. Switch in 4CH. position, "ACTIVE" - All Front and Rear channel inputs.

NOTE: When connecting to the 4-Channel inputs, be sure to route both front and rear RCA cables tightly together.

High Level Input

Connect from source signal by plugging into the RCA input jacks at the amplifier. The input sensitivity ranges from 150mV-12V to accommodate signal from high-level (speaker) input. When utilizing high-level for input signal the auto turn-on feature is active. With the auto turn-on active, the REM becomes an output to turn on/off up to two additional amplifiers or other accessories.

Punch EQ

This works along with the crossover switch on the amplifier. When set to Low-Pass (LP) operation, this is a variable Bass Boost. When set to High-Pass (HP) operation, this is a variable Mid-Bass and Treble Boost. When set to All-Pass (AP) operation, both the Bass and Treble frequencies are boosted. Set this to your personal preference while listening to the system.

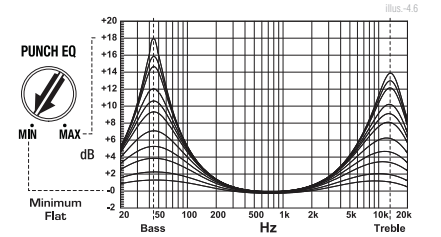

CAUTION Over excursion and subsequent damage may occur at high levels of boost.

Remote Punch Level Control (Option)

NOTE: Previous (prior to 2013) PEQ, Punch Bass and Para-Punch remotes will not work with these amplifiers.

Quick Install:

- Using the screws supplied, install the mounting clip.
- Slip the remote onto the mounting clip until it snaps into place.
- Route and connect the cable to the remote and amplifier.

Operation:

- When connected, the "Subwoofer Level Control" is linked and allows you to remotely control the output level of the amplifier from the dash or center console.

For the T500X1br, the Remote Punch Level Control needs to be switched to the "ON" position for this feature to be active. The T400X2ad needs to be switched to "Low-Pass" for this feature to be active. This feature is not available on the T400X4ad.

NOTE: Use the instructions that came with the remote for a variety of mountings that fit your preference.

Troubleshooting

NOTE: If you are having problems after installation follow the Troubleshooting procedures below.

Check Amplifier for proper connections. Verify that POWER light is on. If POWER light is on skip to Step 3, if not continue.

1. Check in-line fuse on battery positive cable. Replace if necessary.
2. Check fuse(s) on amplifier. Replace if necessary.
3. Verify that Ground connection is connected to clean metal on the vehicle's chassis. Repair/replace if necessary.
4. Verify there is 9 to 14.4 Volts present at the positive battery and remote turn-on cable. Verify quality connections for both cables at amplifier, stereo, and battery/fuse holder. Repair/replace if necessary.

Protect light is on.

1. If the Protect light is on, this is a sign of a possible short in the speaker connections. Check for proper speaker connections and use a volt/ohm meter to check for possible shorts in the speaker wiring. Too low of a speaker impedance may also cause Protect to light.

Check Amplifier for audio output.

1. Verify good RCA input connections at stereo and amplifier. Check entire length of cables for kinks, splices, etc. Test RCA inputs for AC volts with stereo on. Repair/replace if necessary.
2. Disconnect RCA input from amplifier. Connect RCA input from test stereo directly to amplifier input.

Check Amplifier if you experience Turn-on Pop.

1. Disconnect input signal to amplifier and turn amplifier on and off.
2. If the noise is eliminated, connect the REMOTE lead of amplifier to source unit with a delay turn-on module.

OR

1. Use a different 12 Volt source for REMOTE lead of amplifier.

Check Amplifier if you experience excess Engine Noise.

1. Route all signal carrying wires (RCA, Speaker cables) away from power and ground wires.

OR

1. Bypass any and all electrical components between the stereo and the amplifier(s). Connect stereo directly to input of amplifier. If noise goes away the unit being bypassed is the cause of the noise.

OR

1. Remove existing ground wires for all electrical components. Reground wires to different locations. Verify that grounding location is clean, shiny metal free of paint, rust etc.

OR

1. Add secondary ground cable from negative battery terminal to the chassis metal or engine block of vehicle.

OR

1. Have alternator and battery load tested by your mechanic. Verify good working order of vehicle electrical system including distributor, spark plugs, spark plug wires, voltage regulator etc.

Remote not functioning.

1. BD amplifiers remote switch in "ON" position.

OR

2. Remote plugged into remote PLC "IN" port

Remote Lights not functioning.

1. Remote plugged into remote PLC "IN" port

Rockford Corporation offers a limited warranty on Rockford Fosgate products on the following terms:

Length of Warranty

Speakers, Signal Processors, PRIME and PUNCH Amplifiers – 1 Year
 POWER Amplifiers – 2 Years
 Any Factory Refurbished Product – 90 days (receipt required)

What is Covered

This warranty applies only to Rockford Fosgate products sold to consumers by Authorized Rockford Fosgate Dealers in the United States of America or its possessions. Product purchased by consumers from an Authorized Rockford Fosgate Dealer in another country are covered only by that country's Distributor and not by Rockford Corporation.

Who is Covered

This warranty covers only the original purchaser of Rockford product purchased from an Authorized Rockford Fosgate Dealer in the United States. In order to receive service, the purchaser must provide Rockford with a copy of the receipt stating the customer name, dealer name, product purchased and date of purchase.

Products found to be defective during the warranty period will be repaired or replaced (with a product deemed to be equivalent) at Rockford's discretion.

What is Not Covered

1. Damage caused by accident, abuse, improper operations, water, theft, shipping.
2. Any cost or expense related to the removal or reinstallation of product.
3. Service performed by anyone other than Rockford or an Authorized Rockford Fosgate Service Center.
4. Any product which has had the serial number defaced, altered, or removed.
5. Subsequent damage to other components.
6. Any product purchased outside the U.S.
7. Any product not purchased from an Authorized Rockford Fosgate Dealer.

Limit on Implied Warranties

Any implied warranties including warranties of fitness for use and merchantability are limited in duration to the period of the express warranty set forth above. Some states do not allow limitations on the length of an implied warranty, so this limitation may not apply. No person is authorized to assume for Rockford Fosgate any other liability in connection with the sale of the product.

How to Obtain Service

Contact the Authorized Rockford Fosgate Dealer you purchased this product from. If you need further assistance, call 1-800-669-9899 for Rockford Customer Service. You must obtain an RA# (Return Authorization number) to return any product to Rockford Fosgate. You are responsible for shipment of product to Rockford.

EU Warranty

This product meets the current EU warranty requirements, see your Authorized dealer for details.

Installation assistance available at:

RFTECH

www.rockfordfosgate.com/rftech





SETUP DISC



rockfordfosgate.com • 800.669.9899

AUDIO TRACKS

- | | | |
|---------------------------------|-------------------|----------------------------------|
| 1. 3Sixty Level Set | 11. 1kHz / -5dB | 21. Slow Sine Sweep 20Hz – 200Hz |
| 2. 3Sixty OEM Integration | 12. 4kHz / -5dB | 22. Slow Sine Sweep 200Hz – 2kHz |
| 3. Left/Right/Center Channel ID | 13. 40Hz / -10dB | 23. Slow Sine Sweep 2kHz – 20kHz |
| 4. Polarity Pulses | 14. 400Hz / -10dB | 24. Log Swept Chirp |
| 5. 40Hz / 0dB | 15. 1kHz / -10dB | 25. Uncorrelated Pink Noise |
| 6. 400Hz / 0dB | 16. 4kHz / -10dB | 26. Correlated Pink Noise |
| 7. 1kHz / 0dB | 17. 40Hz / -15dB | 27. All Bits High |
| 8. 4kHz / 0dB | 18. 400Hz / -15dB | |
| 9. 40Hz / -5dB | 19. 1kHz / -15dB | |
| 10. 400Hz / -5dB | 20. 4kHz / -15dB | |

CD-ROM CONTAINS:

Product Manual(s)

1600-58530-01



Rockford Fosgate Tempe, AZ, United States

©2013 Rockford Corporation. All Rights Reserved. ROCKFORD FOSGATE, PUNCH and associated logos where applicable are registered trademarks of Rockford Corporation in the United States and/or other countries. All other trademarks are the property of their respective owners. Specifications subject to change without notice.

COMPACT
disc
DIGITAL DATA

SETUP DISC

1. 3Sixty Level Set
2. 3Sixty OEM Integration
3. Left/Right/Center Channel ID
4. Polarity Pulses
5. 40Hz / 0dB
6. 400Hz / 0dB
7. 1kHz / 0dB
8. 4kHz / 0dB
9. 40Hz / -5dB
10. 400Hz / -5dB
11. 1kHz / -5dB
12. 4kHz / -5dB
13. 40Hz / -10dB
14. 400Hz / -10dB

15. 1kHz / -10dB
16. 4kHz / -10dB
17. 40Hz / -15dB
18. 400Hz / -15dB
19. 1kHz / -15dB
20. 4kHz / -15dB
21. Slow Sine Sweep 20Hz-200Hz
22. Slow Sine Sweep 200Hz-2kHz
23. Slow Sine Sweep 2kHz-20kHz
24. Log Swept Chirp
25. Uncorrelated Pink Noise
26. Correlated Pink Noise
27. All Bits High

CD-ROM

Product Manual(s)



COMPACT
disc
DIGITAL DATA

rockfordfosgate.com

600 S. Rockford Drive

Tempe, AZ 85281

1-800-669-9899

©2013 Rockford Corporation. All Rights Reserved.

All trademarks are the property of their respective owners.

CERTIFICATE OF PERFORMANCE VERIFICATION



Model #: **TM400X4AD** Serial #: XXXXXXXXXX Birth Date: **04/16/2015** Test System: **RF-RATS-4**

SYSTEM OPERATION	Idle Current Measure Current Draw at Idle					System Voltage Check System Reference Voltages				
	A PASS					V1 4.954 V2 N/A				
	Bias Set Output Channel Bias					High Rail Voltage Check Amplifier Rail Voltages				
	CH1 N/A CH2 N/A CH3 N/A CH4 N/A					V1 39.64 V2 -39.44 V3 N/A				
	DC Offset Check for No DC Voltage on Outputs					Low Rail Voltage Check Amplifier Rail Voltages				
CH1 .003 CH2 .004 CH3 .004 CH4 .001 CH5 N/A					V1 15.19 V2 -15.59					
Dark Current Current Draw < 100uA					Gain Tracking Check Gain Tracking Between Channels (dB)					
A PASS					CH1 0.948 CH2 0.948 CH3 0.178 CH4 0.178					

SIGNAL	Frequency Response 20Hz-20kHz Sweep @ 1W RMS					High Pass Crossover Check 20Hz-20kHz Sweep @ 1W RMS				
	CH1 PASS CH2 PASS CH3 PASS CH4 PASS CH5 N/A					CH1 PASS CH2 PASS CH3 PASS CH4 PASS CH5 N/A				
	Remote Level & 2/4/5 Ch. Select Check 20Hz-20kHz Sweep @ 1W RMS					Low Pass Crossover & Punch EQ Check 20Hz-20kHz Sweep @ 1W RMS				
	CH1 N/A CH2 N/A CH3 N/A CH4 N/A CH5 N/A					CH1 PASS CH2 PASS CH3 PASS CH4 PASS CH5 N/A				
	Common Mode Rejection Rated 20Hz-20kHz Sweep @ 1W RMS					Channel Separation from Left to Right 20Hz-20kHz Sweep @ Rated RMS Power				
	CH1 PASS CH2 PASS CH3 PASS CH4 PASS CH5 N/A					CH1 PASS CH2 PASS CH3 PASS CH4 PASS CH5 N/A				
Signal to Noise Ratio 20Hz-20kHz Sweep @ Rated RMS Power					Total Harmonic Distortion 20Hz-20kHz Sweep @ 1W RMS (%)					
CH1 PASS CH2 PASS CH3 PASS CH4 PASS CH5 N/A					CH1 0.032 CH2 0.021 CH3 0.031 CH4 0.026 CH5 N/A					
Input Sensitivity Check Sensitivity @ Minimum					Total Harmonic Distortion Rated (%) 20Hz-20kHz Sweep @ Rated RMS Power					
CH1 PASS CH2 PASS CH3 PASS CH4 PASS CH5 N/A					CH1 0.232 CH2 0.209 CH3 0.223 CH4 0.211 CH5 N/A					

RELIABILITY	Short Protect Short All Channels Sequentially @ 1% THD					Thermal Test Thermistor Voltage Check				
	CH1 PASS CH2 PASS CH3 PASS CH4 PASS CH5 N/A					TH1 0.545 TH2 6.460 TH3 0.009 TH4 0.569 TH5 N/A				
	Burn-In Amplifier Accelerated Life Monitor (45 sec. @ 1% THD)									
CH PASS TH PASS V PASS BIAS N/A IR PASS										

POWER	Channel Power Individual Channel Power @ 1% THD @2 Ω					Total Power Total RMS Power @ 1% THD				
	CH1 139 CH2 139 CH3 135 CH4 135 CH5 N/A					546 watts				
	Total Power Total RMS Power @ Each Impedance @ 1% THD									
4Ω 461 2Ω 546 1Ω N/A 2/1Ω N/A										

ALL Rockford Fosgate amplifiers are designed, developed, manufactured and tested in accordance with the CEA-2006 amplifier rating requirements. All tests conducted at 14.4Vdc, Min. Impedance, 1kHz(ab/ad) or 100Hz (bd) unless otherwise stated.
 ©2013 Rockford Corporation. All Rights Reserved. ROCKFORD FOSGATE, and associated logos where applicable are registered trademarks of Rockford Corporation in the United States and/or other countries. All other trademarks are the property of their respective owners. Specifications subject to change without notice.





Are You Engineered to Rock?

Get a One-Year Extended Warranty when you use a matching Rockford Fosgate Amplifier Installation kit with your Amplifier!

We want you to get the performance and reliability that made Rockford Fosgate Amplifiers famous. Using poor-quality under-spec wiring is a guaranteed way to get less than you paid for from your system.

We are so certain that getting your system wired to rock with the right wire and cables will make a difference, that we will give you an additional 1 year warranty on your amp when you use the matching amplifier installation kit. See your dealer to determine the matching kit for your amplifier.

To extend your warranty under this program attach the serial number sticker or UPC code removed from the original amplifier installation kit package in the box below. Keep this form along with your original purchase receipt.

One warranty extension per amplifier regardless of the number of amplifier kits purchased. Amplifier and wiring kit must be purchased at the same time.

What is Covered

This warranty applies only to Rockford Fosgate products sold to consumers by Authorized Rockford Fosgate Dealers in the United States of America or its possessions. Product purchased by consumers from an Authorized Rockford Fosgate Dealer in another country are covered only by that country's Distributor and not by Rockford Corporation.

Who is Covered

This warranty covers only the original purchaser of Rockford product purchased from an Authorized Rockford Fosgate Dealer in the United States. In order to receive service, the purchaser must provide Rockford with a copy of the receipt stating the customer name, dealer name, product purchased and date of purchase. Products found to be defective during the warranty period will be repaired or replaced (with a product deemed to be equivalent) at Rockford's discretion.

What is Not Covered

1. Damage caused by accident, abuse, improper operations, water, theft, shipping
2. Any cost or expense related to the removal or reinstallation of product
3. Service performed by anyone other than Rockford or an Authorized Rockford Fosgate Service Center
4. Any product which has had the serial number defaced, altered, or removed
5. Subsequent damage to other components
6. Any product purchased outside the U.S.
7. Any product not purchased from an Authorized Rockford Fosgate Dealer

Limit on Implied Warranties

Any implied warranties including warranties of fitness for use and merchantability are limited in duration to the period of the express warranty set forth above. Some states do not allow limitations on the length of an implied warranty, so this limitation may not apply. No person is authorized to assume for Rockford Fosgate any other liability in connection with the sale of the product.

How to Obtain Service Under the Extended Warranty Program

The amplifier must be returned by the customer (you) or an authorized Rockford Fosgate retailer with a copy of the original receipt and the ORIGINAL Performance Verification Certificate with the serial number or UPC code from the amp installation kit. Contact your Authorized Rockford Fosgate Dealer or our Customer Support Specialists (1-800-669-9899) for assistance.

EU Warranty

This product meets the current EU warranty requirements, see your Authorized dealer for details. "This Additional One-Year Warranty" is only available where allowed under local laws.

Attach Amplifier Installation Kit
Serial Number or UPC Code from
original packaging here.

**1998 - 2013 H-D
SADDLEBAG LID
SPEAKER KIT**

TMS69BL9813



Introduction

Dear Customer,

Congratulations on your purchase of the world's finest brand of audio products. At Rockford Fosgate we are fanatics about musical reproduction at its best, and we are pleased you chose our product. Through years of engineering expertise, hand craftsmanship and critical testing procedures, we have created a wide range of products that reproduce music with all the clarity and richness you deserve.

For maximum performance we recommend you have your new Rockford Fosgate product installed by an Authorized Rockford Fosgate Dealer, as we provide specialized training through Rockford Technical Training Institute (RTTI). Please read your warranty and retain your receipt and original carton for possible future use.

Great product and competent installations are only a piece of the puzzle when it comes to your system. Make sure that your installer is using 100% authentic installation accessories from Rockford Fosgate in your installation. Rockford Fosgate has everything from RCA cables and speaker wire to power wire and battery connectors. Insist on it! After all, your new system deserves nothing but the best.

To add the finishing touch to your new Rockford Fosgate image order your Rockford accessories, which include everything from T-shirts to hats.

Visit our web site for the latest information on all Rockford products;

www.rockfordfosgate.com

or, in the U.S. call 1-800-669-9899 or FAX 1-800-398-3985. For all other countries, call +001-480-967-3565 or FAX +001-480-966-3983.

Table of Contents

2	Introduction
3	Installation
4	Warranty

If, after reading your manual, you still have questions regarding this product, we recommend that you see your Rockford Fosgate dealer. If you need further assistance, you can call us direct at **1-800-669-9899**. Be sure to have your serial number, model number and date of purchase available when you call.

PRACTICE SAFE SOUND

Continuous exposure to sound pressure levels over 100dB may cause permanent hearing loss. High powered auto sound systems may produce sound pressure levels well over 130dB. Use common sense and practice safe sound.

Safety

This symbol with "WARNING" is intended to alert the user to the presence of important instructions. Failure to heed the instructions will result in severe injury or death.



This symbol with "CAUTION" is intended to alert the user to the presence of important instructions. Failure to heed the instructions can result in injury or unit damage.



- To prevent injury and damage to the unit, please read and follow the instructions in this manual. We want you to enjoy this system, not get a headache.
- If you feel unsure about installing this system yourself, have it installed by a qualified Rockford Fosgate technician.
- Before installation, disconnect the battery negative (-) terminal to prevent damage to the unit, fire and/or possible injury.

Model	TMS69
Nominal Diameter - inch (mm)	6 x 9 (152 x 229)
Description	2-Way
Nominal Impedance (Ohms)	4Ω
Frequency Response (Hz)	56-20kHz
Voice Coil Diameter - inch (mm)	1.4 (35.6)
Power Handling - Watts (RMS/Peak)	100/200
Fs - Free Air Resonance (Hz)	75
Qts	1.63
Vas - cu. ft. (Liter)	0.593 (16.8)
Sensitivity (1W/1M)	89dB
Sensitivity (2.83V/1M)	92dB
Xmax - inch (mm)	0.12 (3)
Mounting Diameter	8.7 x 5.8 (218 x 147)
Mounting Depth	2.8 (71)
Grille/Trim Ring	NO

See page 4 for additional dimensions



CEA 2031

Power handling on Rockford Fosgate speakers conform to CEA-2031 industry standards. This means your speaker has the capacity to handle power under continuous demand, not instantaneous power handling that over time can damage voice coils.



VERIFIED WITH KLIPPEL

To adorn the 'Verified with Klippel' mark, the qualifying company's loudspeaker engineering personnel must be trained and certified by Klippel prior to using the three separate Klippel systems to design, develop and test. Rockford Fosgate has made the investment in Klippel to deliver the best possible speakers and subwoofers to their customers.

Specifications

TMS69

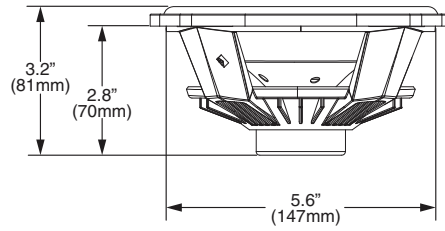
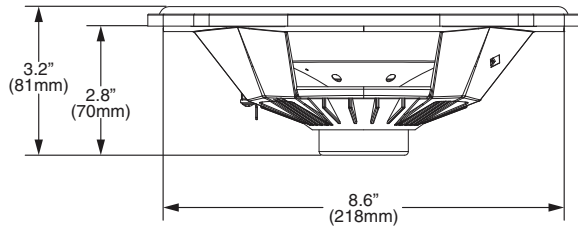
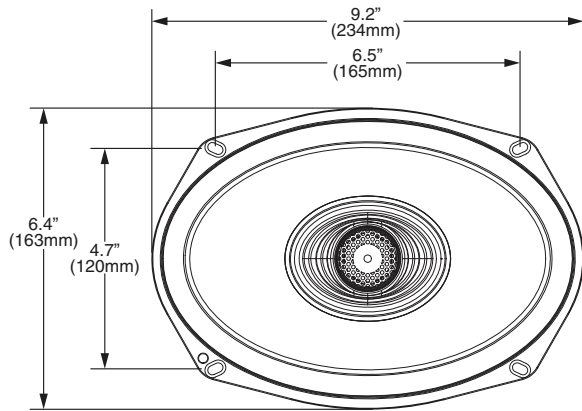

Contents

- (2) TMS69 Speakers
- (2) Speaker Grilles
- (2) Mounting Rings
- (2) Cutting Templates
- (16) Mounting Screws
- (1) Main Harness
- (2) Saddlebag Harnesses
- Plastic Wire Tie Wraps
- Plastic Cable Tie Mounts

Installation Tools

The following is a list of suggested tools needed for installation:

- Drill
- Jigsaw / Airsaw
- 1/8" Drill Bit
- 5/16" Drill Bit
- 3/4" Hole Saw
- Wire Cutters
- Small Flat Blade Screwdriver
- Phillips Screwdriver
- Torx Drivers
- Socket set
- Masking Tape

Installation Considerations

This section focuses on some considerations for installing your Harley-Davidson® saddlebag lid speaker kit.

If you feel unsure about installing this system yourself, have it installed by a qualified technician.

When drilling holes, make sure what is on the other side. Be sure that any electrical, fuel lines or any other important components are free and clear from the area.

⚠ WARNING

Before installation, disconnect the battery negative (-) terminal to prevent damage to the unit, fire and/or possible injury.

⚠ CAUTION

Before beginning any installation, follow these simple rules:

⚠ CAUTION

Be sure to carefully read and understand the instructions before attempting to install these speaker kits.

- Consult your motorcycle's service manual for model specific information. Models may differ from year to year depending on factory options and aftermarket accessories added.
- This speaker kit is specifically designed to work with Rockford Fosgate's Punch® and Power series compact amplifiers.
- With the addition of an amplifier or source unit, be sure that your current charging system is in proper working order.
- Visit rockfordfosgate.com for more comprehensive product information.
- Visit our [YouTube](#) channel for comprehensive installation videos demonstrating complete installation guides and install tips.

NEED HELP WITH YOUR INSTALLATION?



YOUTUBE VISIT OUR CHANNEL FOR A COMPLETE INSTALLATION VIDEO AND OTHER TIPS
WWW.YOUTUBE.COM/USER/ROCKFORDFOSGATE

Applicable Models:

1998 to 2013 Harley-Davidson® Motorcycles with Factory Saddlebags

This saddlebag lid speaker kit is designed to work with Rockford Fosgate's compact chassis Punch® and Power series amplifiers.

- Step 1. Remove the saddlebag lids, seat, gas tank and fairing cover from the motorcycle.
- Step 2. Using masking tape, tape over the painted portion of your saddlebag lids.

NOTE: This will prevent any scratching of the factory paint during the installation process.

NOTE: Be sure the template sits snug on all sides and corners of the saddlebag lid before securing.

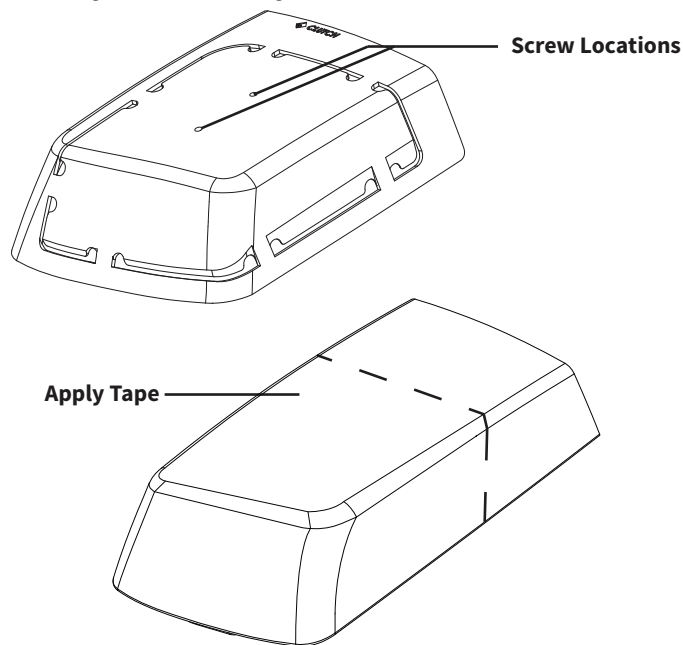

- Step 3. Apply the template to the saddlebag lid and secure using (2) screws that came with the kit.

NOTE: There is a brake and clutch side specific template for each lid. You can use an 1/8" drill bit to predrill holes before screwing the template to the lid. Be sure the template is secured and wont move.

- Step 4. Once the template is secured, use a 5/16" drill bit and drill holes in the template.

NOTE: We suggest drilling at every segment to make sawing easier.

- Step 5. Using a jigsaw, follow along the template.

NOTE: DO NOT cut the segments of the template until all of the slots have been cut. This will help maintain accuracy and fitment for the grilles.

NOTE: When cutting, be sure that the saw blade stays in between the edges of the template. Cutting into the template will lead to fitment issues.

- Step 6. Next you will attach the speaker, grille and mounting ring to the lid using the supplied screws.

Installation

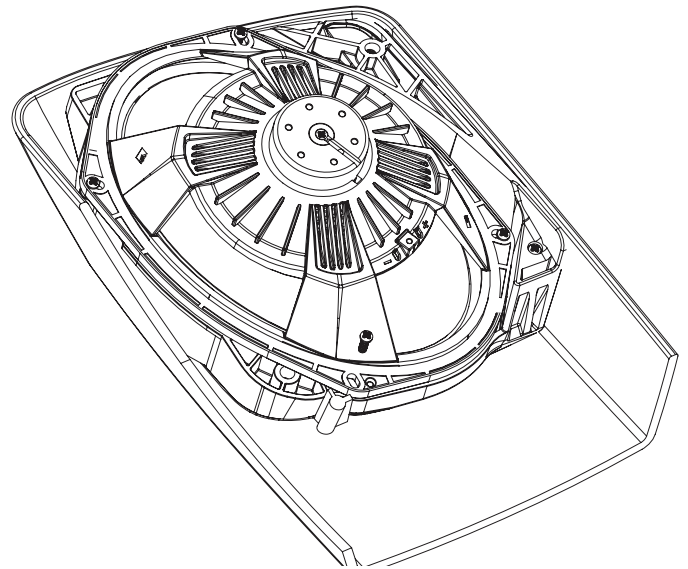
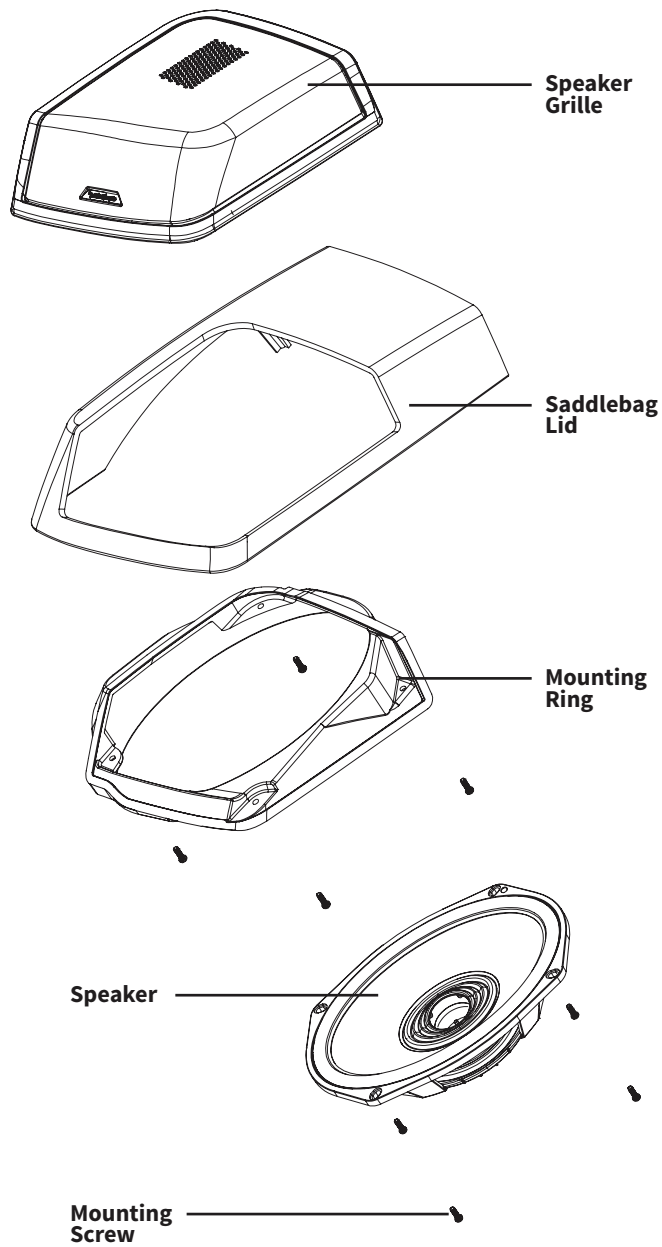

NOTE: It is easiest to place the grill into the hole that has been cut into the lid and place upside down on a bench. Then place the appropriate mounting ring onto the grille, along with the speaker. Secure with the supplied screws.

- Step 7. Run the main harness up the back bone of the bike and to the amplifier under the fairing.
- Step 8. Drill a 3/4" hole on the inside of the bag for the saddlebag harness. Once the hole is drilled, insert through the hole and secure the grommet.
- Step 9. Place the adhesive backed plastic cable tie mounting tab to the inside of the bag.

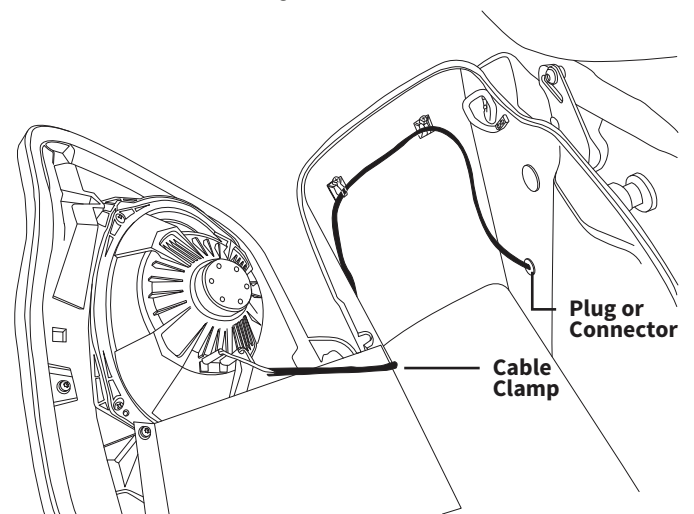

- Step 10. Route the wire along the inside of the bag and secure to the plastic cable tie mounting tab with the supplied plastic wire ties.
- Step 11. Reattach your saddlebag lid and connect the harness to the speaker.
- Step 12. Test system and reassemble the motorcycle.

Warranty

Rockford Corporation offers a limited warranty on Rockford Fosgate products on the following terms:

Length of Warranty

POWER Amplifiers – 2 Years

BMW® Direct Fit Speakers – 2 Years

PUNCH® & PRIME® Amplifiers – 1 Year

Speakers, Signal Processors, Accessories and Capacitors – 1 Year

All marine, motorcycle, motorsport products - 2 Years

Any Factory Refurbished Product – 90 Days (receipt required)

What is Covered

This warranty applies only to Rockford Fosgate products sold to consumers by authorized Rockford Fosgate dealers in the United States of America. Products purchased by consumers from an Authorized Rockford Fosgate Dealer in another country are covered only by that country's Distributor and not by Rockford Corporation.

Who is Covered

This warranty covers only the original purchaser of Rockford product purchased from an authorized Rockford Fosgate dealer in the United States. In order to receive service, the purchaser must provide Rockford with a copy of the receipt stating the customer name, dealer name, product purchased and date of purchase.

Products found to be defective during the warranty period will be repaired or replaced (with a product deemed to be equivalent) at Rockford's discretion.

What is Not Covered

1. Damage caused by accident, abuse, improper installation, operations, theft, water (on non-Element Ready products).
2. Any cost or expense related to the removal or reinstallation of product.
3. Service performed by anyone other than Rockford or an authorized Rockford Fosgate service center.
4. Any product which has had the serial number defaced, altered, or removed.
5. Subsequent damage to other components.
6. Any product purchased outside the U.S.
7. Any product not purchased from an authorized Rockford Fosgate dealer. Refer to rockfordfosgate.com dealer locator for more detail.

Limit on Implied Warranties

Any implied warranties including warranties of fitness for use and merchantability are limited in duration to the period of the express warranty set forth above. Some states do not allow limitations on the length of an implied warranty, so this limitation may not apply. No person is authorized to assume for Rockford Fosgate any other liability in connection with the sale of the product.

How to Obtain Service

Please call 1-800-669-9899 for Rockford Customer Service. You must obtain an RA# (Return Authorization number) to return any product to Rockford Fosgate. You are responsible for shipment of product to Rockford.

EU Warranty

This product meets the current EU warranty requirements, see your Authorized dealer for details.

— Installation assistance available at: —

RFTECH

— www.rockfordfosgate.com/rftech —

072717 1230-61983-01-A

Printed In China

600 South Rockford Drive • Tempe, Arizona 85281 United States
Direct: (480) 967-3565 • Toll Free: (800) 669-9899

ROCKFORDFOSGATE.COM



1998-2013
HARLEY-DAVIDSON®
AMPLIFIER INSTALL KIT

RFK-HD9813

Serial Number: _____

Date of Purchase: _____

Introduction

Dear Customer,

Congratulations on your purchase of the world's finest brand of audio products. At Rockford Fosgate we are fanatics about musical reproduction at its best, and we are pleased you chose our product. Through years of engineering expertise, hand craftsmanship and critical testing procedures, we have created a wide range of products that reproduce music with all the clarity and richness you deserve.

For maximum performance we recommend you have your new Rockford Fosgate product installed by an Authorized Rockford Fosgate Dealer, as we provide specialized training through Rockford Technical Training Institute (RTTI). Please read your warranty and retain your receipt and original carton for possible future use.

Great product and competent installations are only a piece of the puzzle when it comes to your system. Make sure that your installer is using 100% authentic installation accessories from Rockford Fosgate in your installation. Rockford Fosgate has everything from RCA cables and speaker wire to power wire and battery connectors. Insist on it! After all, your new system deserves nothing but the best.

To add the finishing touch to your new Rockford Fosgate image order your Rockford accessories, which include everything from T-shirts to hats.

Visit our web site for the latest information on all Rockford products; www.rockfordfosgate.com

or, in the U.S. call 1-800-669-9899 or FAX 1-800-398-3985. For all other countries, call +001-480-967-3565 or FAX +001-480-966-3983.

Table of Content

2	Introduction
3-5	Contents
5	Warranty

If, after reading your manual, you still have questions regarding this product, we recommend that you see your Rockford Fosgate dealer. If you need further assistance, you can call us direct at **1-800-669-9899**. Be sure to have your serial number, model number and date of purchase available when you call.

Safety

This symbol with "WARNING" is intended to alert the user to the presence of important instructions. Failure to heed the instructions will result in severe injury or death.

This symbol with "CAUTION" is intended to alert the user to the presence of important instructions. Failure to heed the instructions can result in injury or unit damage.

- To prevent injury and damage to the unit, please read and follow the instructions in this manual. We want you to enjoy this system, not get a headache.

- If you feel unsure about installing this system yourself, have it installed by a qualified Rockford Fosgate technician.
- Before installation, disconnect the battery negative (-) terminal to prevent damage to the unit, fire and/or possible injury

PRACTICE SAFE SOUND

Continuous exposure to sound pressure levels over 100dB may cause permanent hearing loss. High powered auto sound systems may produce sound pressure levels well over 130dB. Use common sense and practice safe sound.

Contents

Installation Considerations

 **WARNING**

This section focuses on some considerations for installing your motorcycle amplifier installation kit. This manual will illustrate the installation of two different fairing styles offered by Harley-Davidson® from the production years ranging from 1998 to 2013. (Ultra Classic®, Electra Glide®, Street Glide®, Tri Glide®, Road Glide®, Road Glide Ultra® and CVO™.)

 **CAUTION**

If you feel unsure about installing this system yourself, have it installed by a qualified technician.

Before installation, disconnect the battery negative (-) terminal to prevent damage to the unit, fire and/or possible injury.

Before beginning any installation, follow these simple rules:

- Be sure to carefully read and understand the instructions before attempting to install this motorcycle audio kit.
- Consult your motorcycle's service manual for model specific information. Models may differ from year to year depending on factory options and aftermarket accessories added.
- This motorcycle amplifier installation kit is specifically designed to work with Rockford Fosgate's POWER and PUNCH® compact chassis amplifiers in both 2 or 4-channel configurations.
- With the addition of an amplifier, be sure that your current charging system is in proper working order.
- Utilize a blanket or fender cover to protect the front fender from tools or any other items that may be accidentally dropped while removing the fairing.
- Visit rockfordfosgate.com for more comprehensive installation videos and product information.

Contents

- (1) Power Harness
- (1) Front Input Harness
- (1) Front Output Harness
- (2) Rear Speaker Harness
- (2) Speaker Output Y-Adapter
- (8) Wire Zip Tie Wraps
- (4) Amp Screws
- (6) Road Glide® Heat Sink Screws
- (2) Road Glide® Amp Mounting Brackets
- (2) Street Glide® Heat Sink Screws
- (2) Street Glide® Threaded Studs
- (1) Street Glide® Amp Mounting Bracket
- (1) Amp Heat Sink

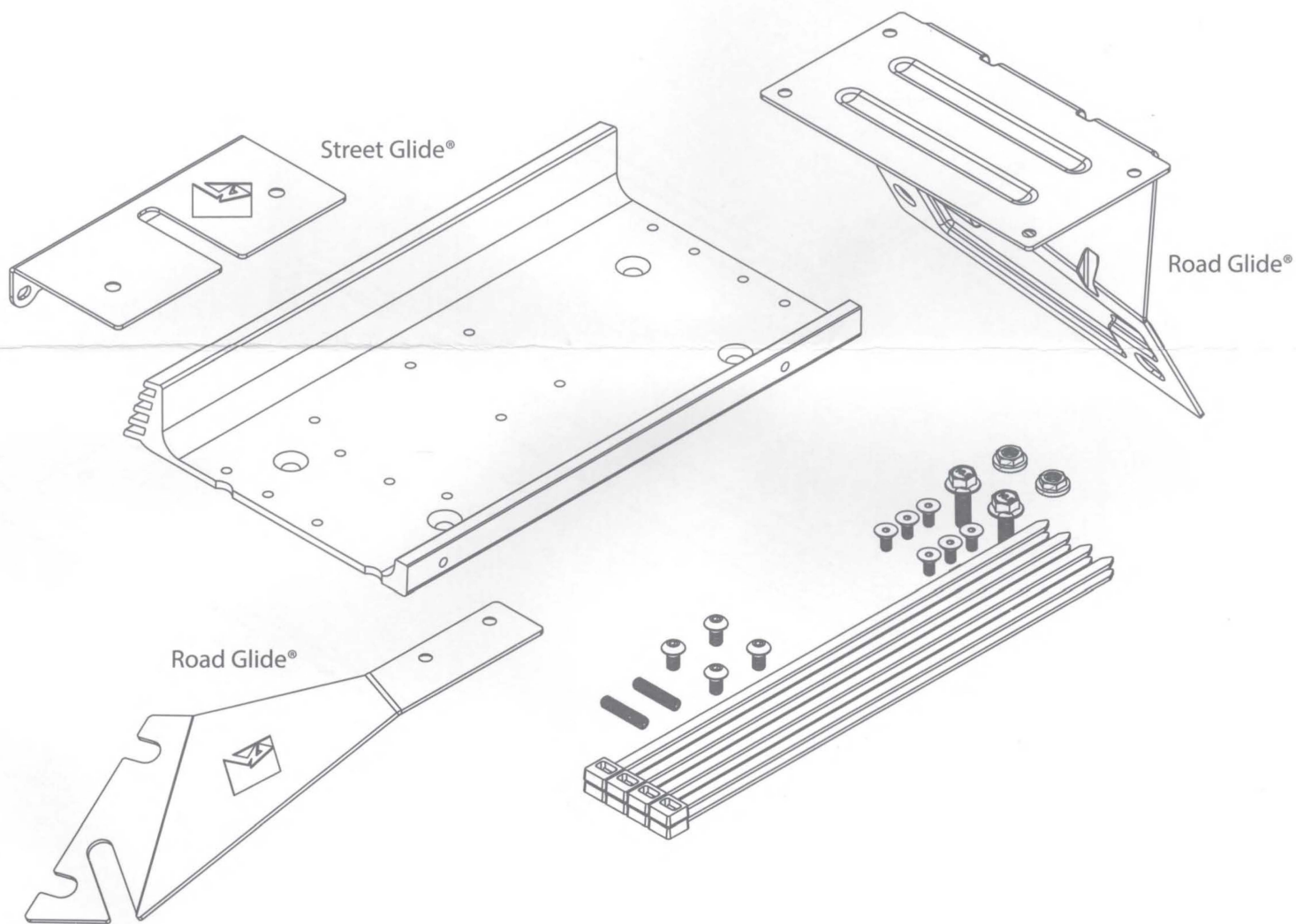

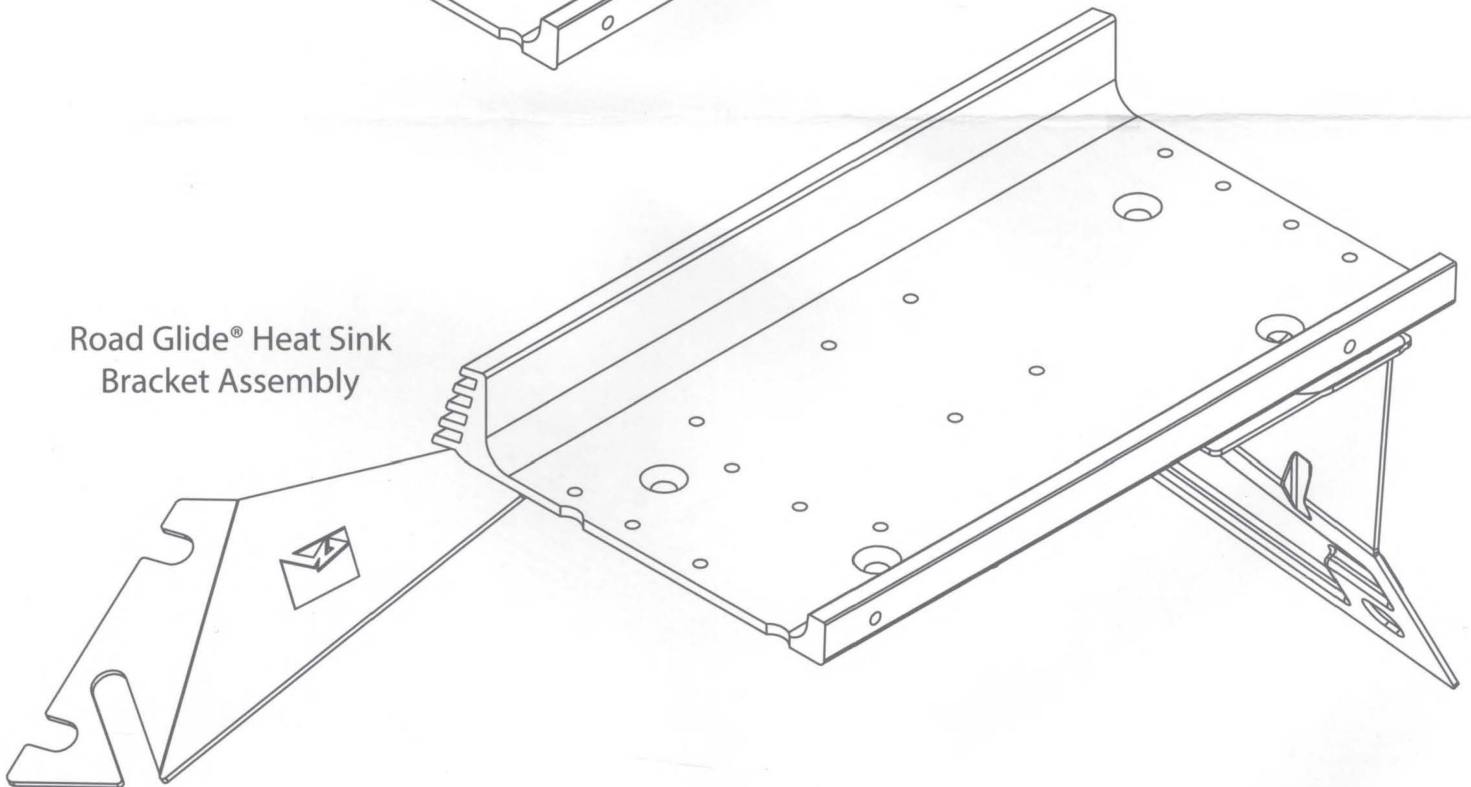
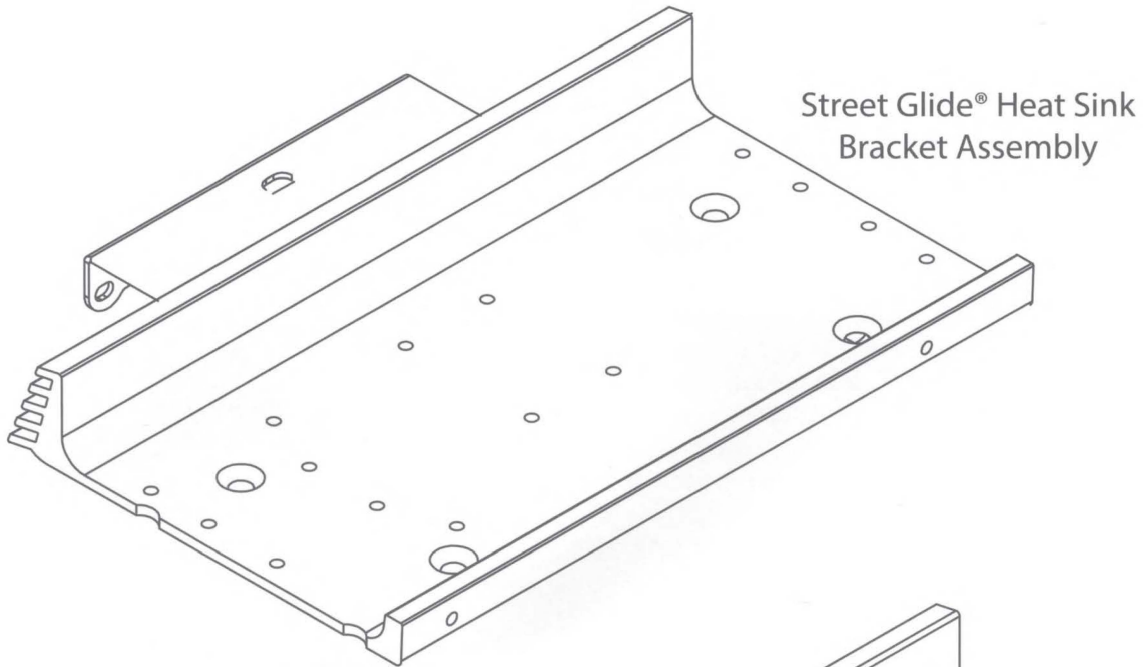

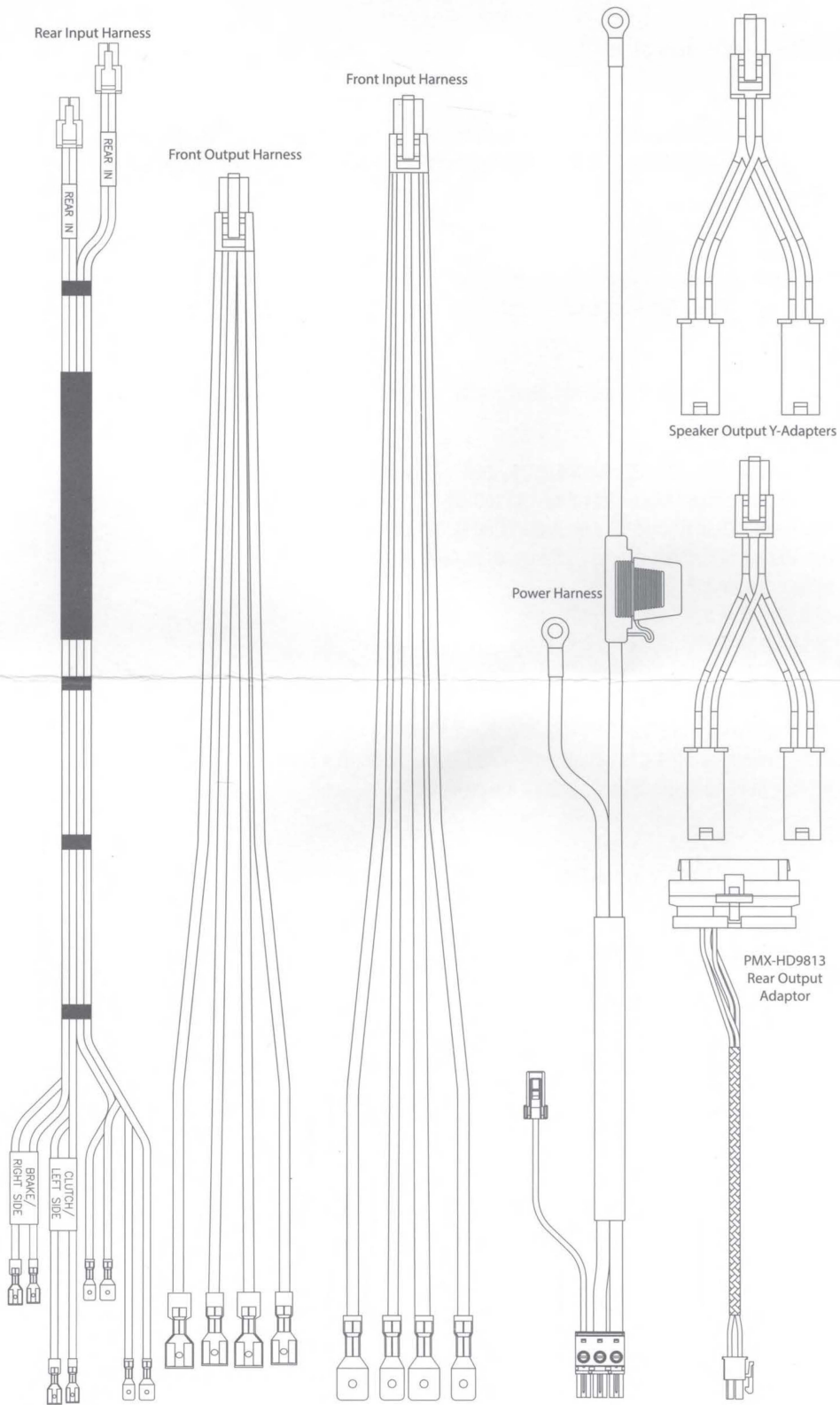

Warranty

Rockford Corporation offers a limited warranty on Rockford Fosgate products on the following terms:

Length of Warranty

- POWER Amplifiers – 2 Years
- BMW® Direct Fit Speakers – 2 Years
- All other products - 1 Year
- Any Factory Refurbished Product – 90 days (receipt required)

What is Covered

This warranty applies only to Rockford Fosgate products sold to consumers by Authorized Rockford Fosgate Dealers in the United States of America or its possessions. Product purchased by consumers from an Authorized Rockford Fosgate Dealer in another country are covered only by that country's Distributor and not by Rockford Corporation.

Who is Covered

This warranty covers only the original purchaser of Rockford product purchased from an Authorized Rockford Fosgate Dealer in the United States. In order to receive service, the purchaser must provide Rockford with a copy of the receipt stating the customer name, dealer name, product purchased and date of purchase.

Products found to be defective during the warranty period will be repaired or replaced (with a product deemed to be equivalent) at Rockford's discretion.

What is Not Covered

1. Damage caused by accident, abuse, improper operations, water, theft, shipping.
2. Any cost or expense related to the removal or reinstallation of product.
3. Service performed by anyone other than Rockford or an Authorized Rockford Fosgate Service Center.
4. Any product which has had the serial number defaced, altered, or removed.
5. Subsequent damage to other components.
6. Any product purchased outside the U.S.
7. Any product not purchased from an Authorized Rockford Fosgate Dealer.

Limit on Implied Warranties

Any implied warranties including warranties of fitness for use and merchantability are limited in duration to the period of the express warranty set forth above. Some states do not allow limitations on the length of an implied warranty, so this limitation may not apply. No person is authorized to assume for Rockford Fosgate any other liability in connection with the sale of the product.

How to Obtain Service

Contact the Authorized Rockford Fosgate Dealer you purchased this product from. If you need further assistance, call 1-800-669-9899 for Rockford Customer Service. You must obtain an RA# (Return Authorization number) to return any product to Rockford Fosgate. You are responsible for shipment of product to Rockford.

EU Warranty

This product meets the current EU warranty requirements, see your Authorized dealer for details.

Installation assistance available at:

RFTECH

www.rockfordfosgate.com/rftech

031919JF

1230-72551-01-A

Printed in China

600 South Rockford Drive • Tempe, Arizona 85281 United States
Direct: (480) 967-3565 • Toll Free: (800) 669-9899

ROCKFORDFOSGATE.COM



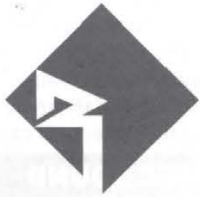

Rockford Fosgate®

**DIGITAL MEDIA RECEIVER
FOR 1998-2013 HARLEY-
DAVIDSON® MOTORCYCLES**

P U N C H®

PMX-HD9813



pandora®



Introduction

Dear Customer,

Congratulations on your purchase of the world's finest brand of audio products. At Rockford Fosgate we are fanatics about musical reproduction at its best, and we are pleased you chose our product. Through years of engineering expertise, hand craftsmanship and critical testing procedures, we have created a wide range of products that reproduce music with all the clarity and richness you deserve.

For maximum performance we recommend you have your new Rockford Fosgate product installed by an Authorized Rockford Fosgate Dealer. Please read your warranty and retain your receipt and original carton for possible future use.

Great product and competent installations are only a piece of the puzzle when it comes to your system. Make sure that your installer is using 100% authentic installation accessories from Rockford Fosgate in your installation. Rockford Fosgate has everything from RCA cables and speaker wire to power wire and battery connectors. Insist on it! After all, your new system deserves nothing but the best.

To add the finishing touch to your new Rockford Fosgate image, order your Rockford accessories, which include everything from T-shirts to hats.

Visit our web site for the latest information on all Rockford products;
www.rockfordfosgate.com
or, in the U.S. call 1-800-669-9899 or FAX 1-800-398-3985. For all other countries, call +001-480-967-3565 or FAX +001-480-966-3983.

Table of Contents

2	Introduction
3	Specifications
4	Design Features
5	Installation/Mounting
6-10	Operation
	Settings
	Tuner (AM/FM)
	USB-iPod
	AUX (Auxiliary Input)
	Bluetooth*
	Pandora*
	SiriusXM*
11	PMX-BTUR Function Table
12-13	Troubleshooting
14-53	French, Spanish, German & Italian
54	Limited Warranty Information

If, after reading your manual, you still have questions regarding this product, we recommend that you see your Rockford Fosgate dealer. If you need further assistance, you can call us directly at 1-800-669-9899. Be sure to have your serial number, model number and date of purchase available when you call.

PRACTICE SAFE SOUND

Continuous exposure to sound pressure levels over 100dB may cause permanent hearing loss. High powered auto sound systems may produce sound pressure levels well over 130dB. Use common sense and practice safe sound.

Safety

This symbol with "WARNING" is intended to alert the user to the presence of important instructions. Failure to heed the instructions could result in severe injury or death.



WARNING

This symbol with "CAUTION" is intended to alert the user to the presence of important instructions. Failure to heed the instructions could result in injury or unit damage.



CAUTION

To prevent injury and damage to the unit, please read and follow the instructions in this manual.

If you feel unsure about installing this system yourself, have it installed by a qualified Rockford Fosgate dealer.

Before installation, disconnect the battery negative (-) terminal to prevent damage to the unit, fire and/or possible injury.

FCC Compliance Statement

FCC ID: 2AB7S-CW51P

This equipment has been tested and found to comply with the limits for a Class B digital device, pursuant to part 15 of the FCC Rules. These limits are designed to provide more reasonable protection against harmful interference in a residential installation.

Operation is subjected to the following two conditions: (1) This device may not cause harmful interference, and (2) the device must accept any interference received, including interference that may cause undesired operation.

This equipment generates, uses, and can radiate radio frequency energy and, if not installed and used in accordance with the instructions, may cause harmful interference to radio communications. However, there is no guarantee that interference will not occur in a particular installation. If this equipment does cause harmful interference to radio or television reception, which can be determined by turning the equipment off and on, you are encouraged to try to correct the interference by one of the following measures:

- Reorient or relocate the receiving antenna.
- Increase the separation between the equipment and receiver.
- Consult your Rockford Fosgate dealer.

©2019 Rockford Corporation. All Rights Reserved. PUNCH® and associated logos where applicable, are registered trademarks of Rockford Corporation in the United States and/or other countries. iPhone and iPod are trademarks of Apple Inc., registered in the U.S. and other countries. The Bluetooth® word mark and logos are registered trademarks owned by Bluetooth SIG, Inc. and any use of such marks by Rockford Corporation is under license. All other trademarks are the property of their respective owners. Specifications subject to change without notice.

"Made for iPod" and "Made for iPhone" mean that an electronic accessory has been designed to connect specifically to iPod, or iPhone, respectively, and has been certified by the developer to meet Apple performance standards. Apple is not responsible for the operation of this device or its compliance with safety and regulatory standards. Please note that the use of this accessory with iPod or iPhone may affect wireless performance.

Pandora, the Pandora logo, and the Pandora trade dress are trademarks or registered trademarks of Pandora Media, LLC. Used with permission. Pandora is only available in certain countries. Please visit <http://www.pandora.com/legal> for more information.

Sirius, XM and all related marks and logos are trademarks of Sirius XM Radio Inc. All rights reserved.

Model	PMX-HD9813																
Operating Voltage	10.5V - 16V																
Fuse Rating	20A																
Power Output	25 W X 4 @ 4 Ohms RMS 50 W x 4 @ 2 Ohms Peak																
Max. RCA Output Voltage	4V																
Output Impedance	500Ω																
Frequency Response	20 - 20kHz																
FM Frequency Range	87.5MHz - 107.9MHz																
AM Frequency Range	530kHz - 1710kHz																
Tuner Presets	18 FM / 12 AM																
Clock	12:00/24Hour																
Display	3" Color TFT																
Bluetooth	3.0+EDR, A2DP 1.3																
USB Compatibility	2.0																
USB Capacity	32 GB max, 255 Folders max, 999 Songs max																
USB Output	1.5A																
Made for iPhone Model Names-	<table border="0"> <tr> <td>iPhone XS Max</td> <td>iPhone 7</td> </tr> <tr> <td>iPhone XS</td> <td>iPhone 6s Plus</td> </tr> <tr> <td>iPhoneXR</td> <td>iPhone 6s</td> </tr> <tr> <td>iPhone X</td> <td>iPhone 6 Plus</td> </tr> <tr> <td>iPhone 8 Plus</td> <td>iPhone 6</td> </tr> <tr> <td>iPhone 8</td> <td>iPhone 5S</td> </tr> <tr> <td>iPhone 7 Plus</td> <td>iPhone 5C</td> </tr> <tr> <td></td> <td>iPhone 5</td> </tr> </table>	iPhone XS Max	iPhone 7	iPhone XS	iPhone 6s Plus	iPhoneXR	iPhone 6s	iPhone X	iPhone 6 Plus	iPhone 8 Plus	iPhone 6	iPhone 8	iPhone 5S	iPhone 7 Plus	iPhone 5C		iPhone 5
iPhone XS Max	iPhone 7																
iPhone XS	iPhone 6s Plus																
iPhoneXR	iPhone 6s																
iPhone X	iPhone 6 Plus																
iPhone 8 Plus	iPhone 6																
iPhone 8	iPhone 5S																
iPhone 7 Plus	iPhone 5C																
	iPhone 5																
Android Compatibility	Bluetooth® Only																
Audio File Compatibility	MP3, WMA, FLAC																
Certifications	ASTM D4329 IPX6 (Front Face) IPX4 (Rear Chassis) CISPR25 Class 3 EMI FCC, CE RED, IC RCM																
Compatibility	2006-2013 Street Glide 1998-2013 Road Glide 1998-2013 Electra Glide Not compatible with factory equipped CB, Headset, Satellite radio systems or Rear Volume Controls																



CEA 2006

Power ratings on Rockford Fosgate source units conform to CEA-2006 industry standards. These guidelines mean your source unit's output power ratings are REAL POWER numbers, not inflated marketing ratings.

Design Features

SRC (Power) Button

This button allows you to switch between sources and power the unit ON and OFF.

Rotary Encoder

This knob is for adjusting main volume, menu navigation and setting adjustments.

PLAY / PAUSE button

Press this button to play or pause your music. This button also acts as a MUTE when the source is in AUX & TUNER mode.

PRESET buttons

These buttons allow you to set presets and allow quick access to them once set. Press and hold to retain the channel and press to recall the channel.

MENU button

Press & hold for 5 seconds to access the main menu settings. Pressing will give you access to the settings for the active source.

SUB Buttons

These buttons allow you to adjust the subwoofer output UP or DOWN (0-20).

REV / FWD button

Use this button to skip back and forward through channels or tracks with a press. Holding the button down will activate manual seek mode.

DIMMER button

Pressing this button will allow you to select between the two brightness values for the display.

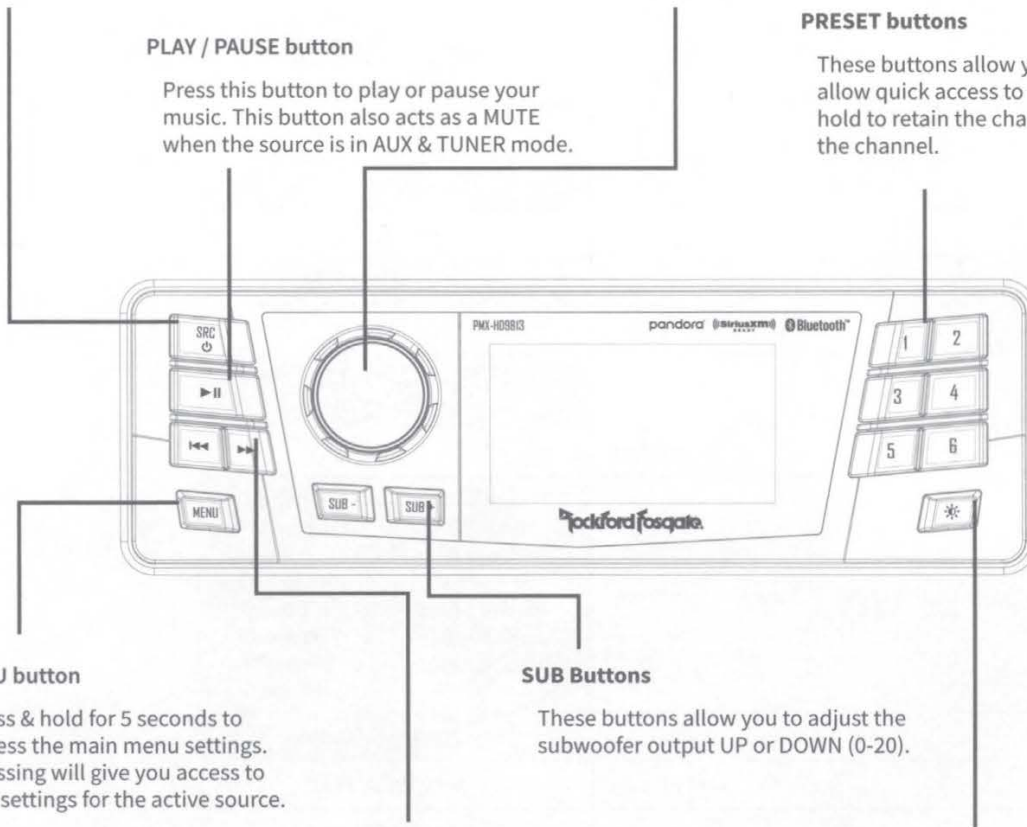

Fig. 1

• Contents

- Source Unit
- Installation & Operation Manual
- RCA Output Harness

Installation Considerations

The following is a basic list of tools needed for installation:

- Volt/Ohm meter
- T-25 Torx Bit
- Battery post wrench
- 3/16" Allen Wrench

If you feel unsure about installing this system yourself, have it installed by a qualified Rockford Fosgate dealer.

Before installation, disconnect the battery negative (-) terminal to prevent damage to the unit, fire and/or possible injury.

For your specific radio installation, please refer to www.rockfordfosgate.com/products/details/pmx-hd9813 for more information.

If installing this unit in a motorcycle that no longer has the factory radio harness and connectors or if adding rear speakers to a motorcycle not equipped with them, please contact Rockford Fosgate to purchase the harness (part # 1130-72997-01).

Mounting

This unit is a direct plug and play replacement for the factory radio.

1. Using your Torx tool, remove the fairing screws securing the outer fairing to the bike. This will give you access to the factory radio.
2. Remove the (4) factory screws that are holding the radio in place using the 3/16" allen tool. There are (2) on each side.
3. Carefully unplug the factory harness and antenna from the back of the factory radio.
4. Remove the radio by pulling it towards the front of the motorcycle.
5. Slide the PMX-HD9813 source unit into the factory radio mounting hole and secure with existing factory fasteners.
6. Plug the factory harness and antenna into the back of the new unit.
7. If using a non Rockford Fosgate amplifier, plug the RCA harness into the remaining socket. See illus-1.1.
8. If using an AUX to plug into the unit, plug the RCA harness into the remaining socket. See illus - 1.1.
9. If installing a SiriusXM Connect Tuner and antenna, you must plug the SXV300 tuner into the SiriusXM port. See illus 1.1
10. If using the Rockford Fosgate amplified kit, please refer to the video on www.rockfordfosgate.com/motorcycle
11. Reinstall the fairing onto the bike.

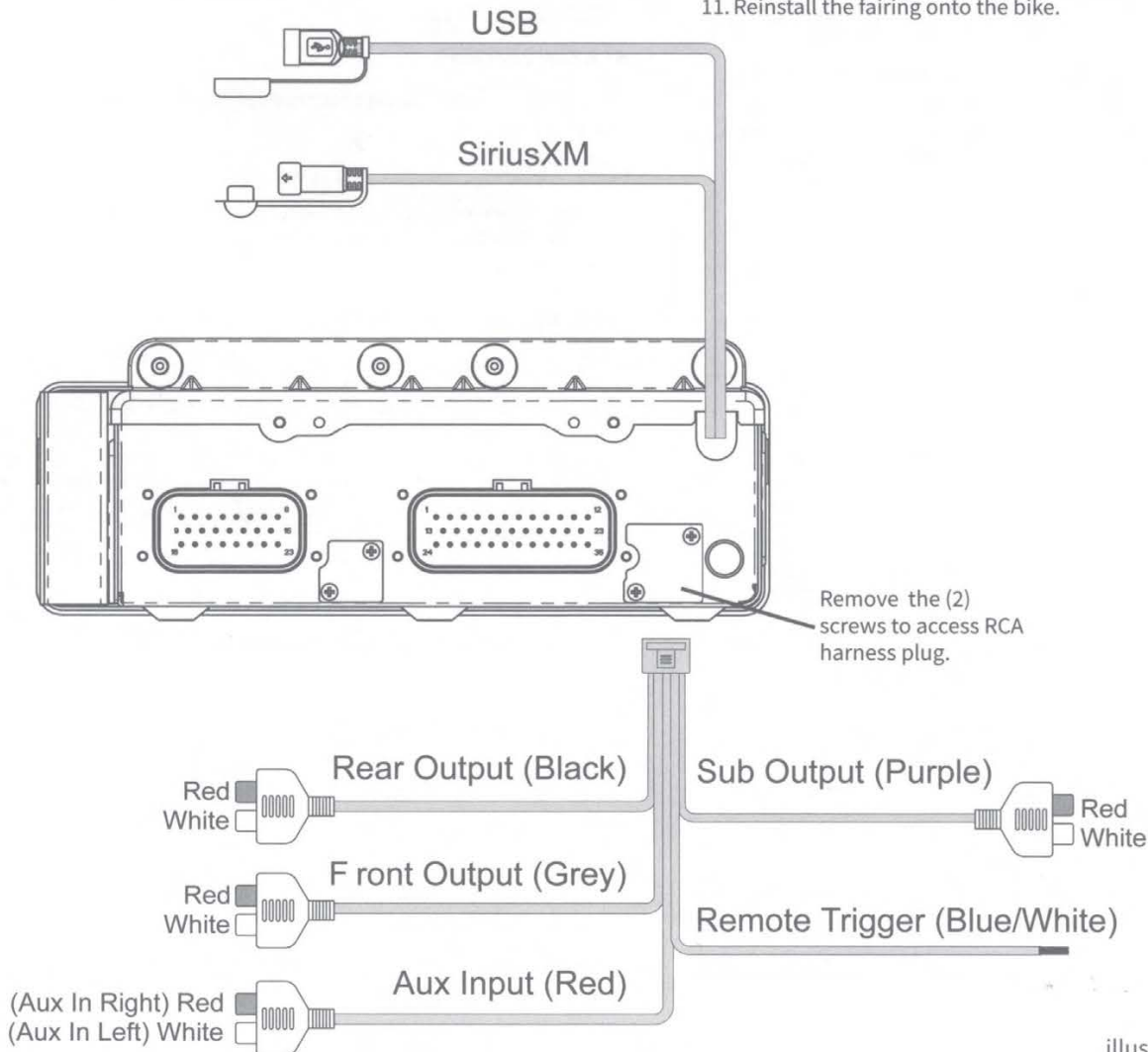

illus.-1.1

Settings



Source Unit Settings

To access the source unit's settings, press and hold the MENU button until the options appear. Rotate the encoder to scroll through the list of settings and then press the encoder button to select the setting you wish to change. (BALANCE>FADER>AUDIO>VOLTAGE GAUGE>BT PAIRING>BEEP>TUNER REGION>SOFTWARE>THEME>REMOTE SETUP>CLOCK/DATE>FACTORY DEFAULT)

BALANCE

Press the encoder button to access BALANCE adjustment settings. Rotate the encoder button to set output BALANCE.

FADER

Press the encoder button to access FADER adjustment settings. Rotate the encoder button to set output FADER.

AUDIO

To access the AUDIO settings, press the AUDIO option from the MENU screen. Rotate the encoder to scroll through the list of settings and then press the encoder button to select the setting you wish to change. (7 BAND EQ>CROSSOVER>PEQ>REAR RCA>AUX INPUT>SOURCE GAIN>INTERNAL AMPLIFIER)

7 BAND EQ

Press the encoder button to access the 7 BAND EQ settings. Use the rotary encoder to scroll through the EQ settings. (FLAT > ROCK > CLASSIC > ACOUSTIC > DANCE > ELECTRONIC > HIP-HOP > CUSTOM) When setting up the CUSTOM EQ, press the encoder button to set the first frequency. Once active, rotate the encoder to adjust the frequency settings. Press encoder button again to access the next frequency. Repeat until all EQ settings are complete. Press the MENU button to exit and go back up one level.

CROSSOVER

Press to access the CROSSOVER settings. Use the rotary encoder to select the crossover zone options (FRONT>REAR>SUB). Press the encoder to adjust the frequency of the crossover (60Hz>80Hz>120Hz>APF). Press MENU to exit and go back up one level.

PUNCH EQ

Press to access the PUNCH EQ settings. Use the rotary encoder to adjust the gain output (0-12). Press MENU to exit and go back up one level.

Punch EQ is an onboard equalizer with up to +18dB @ 45Hz and/or up to +12dB boost at 12.5kHz

AUX INPUT

RENAME – To rename AUX, press the encoder button to set the first letter of the new name. Once active, rotate encoder to select letters. Press the encoder button again to set the next letter. Repeat until AUX has been renamed. Press MENU to exit and go back up one level.

ENABLE - Press the encoder button to access options. Rotate the encoder button to select if unit is discoverable. (ENABLE > DISABLE)

SOURCE GAIN

To adjust the level of device input gain, scroll through the inputs (FM TUNER>AM TUNER>USB>AUX1>AUX2>BLUETOOTH>PANDORA>SiriusXM>GLOBAL INPUT) to the device you want to adjust, press the encoder button to access the gain settings. Rotate the encoder button to set the level of gain (-3dB > -2dB > -1dB > 0dB > +1dB > +2dB > +3dB).

Selecting the GLOBAL INPUT option lets you adjust all source attenuation at once (0dB>-3dB>-6dB>-9dB>-12dB>-15dB>-18dB).

INTERNAL AMPLIFIER

Press to access the INTERNAL AMPLIFIER options. Use the rotary encoder to select options (ON>OFF). When using an amplifier to power your speakers, select OFF. If you are powering your speakers directly from the source unit, select the INTERNAL AMPLIFIER to ON.

VOLTAGE GAUGE

To display the vehicle voltage, press the encoder button on the VOLTAGE GAUGE option.

BT DEVICE PAIRING

Press the encoder button to access options (DISCOVERABLE > DEVICE).

DISCOVERABLE

Rotate the encoder button to select if unit is discoverable for pairing. (ENABLE > DISABLE) Once enabled, the source unit is now discoverable and ready for pairing to your mobile device. Open the Bluetooth settings on your mobile device to find the source unit labeled "Rockford PMX" and select.

DEVICE

Selecting DEVICE by pressing the encoder button will allow you to rename the source unit with up to 16 characters. This gives you the ability to have a unique name for easy identification during device pairing. Press the encoder button to select the letter to be changed and rotate the knob to change the value. Repeat process until desired name is reached.

BEEP

Press the encoder button to access the BEEP options. Rotate the encoder button to turn system beep ON/ OFF.

TUNER REGION

To adjust, press the encoder button to access. Rotate the encoder button to select the TUNER REGION of your preference. (EUROPE > USA > RUSSIA > LATIN > ASIA > JAPAN > MIDEAST > AUSTRALIA)

SOFTWARE

VERSION - Press the encoder button to display the current firmware version of the unit.

UPDATE - Press the encoder button to update the firmware. Follow the instructions on the screen when updating.

THEME

To adjust the THEME, press the encoder to access the feature. Rotate the encoder button to select the desired THEME (DAY, NIGHT, AUTO)

REMOTE SETUP FOR OPTIONAL PMX-BTUR

To access the REMOTE SETUP options, press the encoder to display the different options (HEAD UNIT INFO>PMX-BTUR SCAN>DISCONNECT>PMX-BTUR INFO> HEAD UNIT RESET).

To pair you PMX-BTUR, press any button on the remote to activate the device. Then select PMX-BTUR SCAN under the REMOTE SETUP options. Once it detects the remote, press the encoder to finish pairing. Refer to the table on page 11 for PMX-BTUR controls.

CLOCK/DATE

To adjust the CLOCK/DATE, press the encoder to access the feature. Rotate the encoder button to select CLOCK/DATE options (CLOCK/DATE SETTING>ALBUM ART DISPLAY).

CLOCK/DATE SETTING

To set the 12H/24H display preference, rotate the encoder to scroll through the time display options. Press encoder to select and keep that option.

To adjust the time, rotate the encoder to the correct hour, press the encoder to lock in hour, repeat for minutes and date.

ALBUM ART DISPLAY

Press the encoder button to select which ALBUM ART DISPLAY option you want (OFF>5S>10S>20S>ALWAYS).

FACTORY DEFAULT

AUDIO - Press the encoder button to access. Rotate the encoder button to select YES/NO. Selecting YES will reset your unit back to factory default settings.

SYSTEM - Press the encoder button to access. Rotate the encoder button to select YES/NO. Selecting YES will reset your unit back to factory default settings.

SiriusXM - Press the encoder button to access. Rotate the encoder button to select YES/NO. Selecting YES will reset your unit back to factory default settings.

Basic Operation**TURNING THE UNIT ON / OFF**

Press and hold the SRC (Power) button to turn the unit ON or OFF

ADJUSTING THE VOLUME

Rotate encoder knob left or right to desired volume level (0-40). The current volume level will be displayed during adjustment.

ADJUSTING THE SUBWOOFER OUTPUT

Press the SUB + or SUB- buttons to adjust the output level (0-20).

ADJUSTING THE SCREEN BRIGHTNESS

Press and hold the DIMMER button to adjust the brightness level. There are two brightness levels.

SELECTING A SOURCE TO PLAY

Press the SRC button to show the different source options (FM TUNER>AM TUNER>USB>AUX>BLUETOOTH>PANDORA>SiriusXM). Use the rotary encoder or press the SRC button to scroll through sources.

**Tuner Operation (FM/AM)**

To operate, use the rotary encoder to select the tuner source you want to listen to (FM>AM>WB).

To switch between AUTO and MANUAL SEEK modes, press and hold either the FWD or REV buttons.

To AUTO SEEK stations, press the FWD and REV buttons. To MANUAL SEEK stations, press and hold the FWD and REV buttons to tune to the desired frequency.

To MUTE the TUNER, press the PLAY/PAUSE button.

FM BAND SETTINGS

To access the FM BAND SETTINGS, press the MENU when using the FM TUNER source. This will give you access to the settings specific to the FM TUNER (FM>PRESETS>ADD PRESETS>REMOVE PRESETS>AUTO STORE>LOCAL).

PRESETS

Press the encoder button to access the PRESETS list. Using this feature allows you to see what PRESETS are saved on the unit.

ADD PRESETS

Press the encoder button on the ADD PRESETS option. You will need to be on both the station and PRESET group you want to add first (FM1>FM2>FM3). Using this feature allows you to save stations to the unit. Once selected, use the rotary encoder to select the PRESET number (1-6) you want the station saved to.

REMOVE PRESETS

Press the encoder button on the REMOVE PRESETS option. You will need to be under the PRESET group you want to adjust first (FM1>FM2>FM3). Using this feature allows you to remove saved stations on the unit. Once selected, use the rotary encoder to select the PRESET number (1-6) of the station you want removed.

FM

Press the encoder button to access the FM PRESET options (FM1>FM2>FM3). Using this feature allows you to have separate tuner preset groups to choose from. Use the rotary encoder button to scroll through the TUNER groups and press to select the group.

AUTO STORE

Press the encoder button to access the AUTO STORE function. You will need to be under the PRESET group you want to adjust first (FM1>FM2>FM3). This feature automatically stores presets on the unit. It will stop when presets 1-6 are set. Select the next PRESET group and repeat to fill next set.

LOCAL

Press the encoder button to access the LOCAL options. Once selected, use the rotary encoder to select ON or OFF. The local option tunes to nearby radio stations with sufficiently strong

Operation

signals for good reception. In areas where reception is poor, switching to distance tuning enables the unit to tune in to more distant stations. Distance tuning is the default.

AM BAND SETTINGS

To access the AM BAND SETTINGS, press the MENU when using the AM TUNER source. This will give you access to the settings specific to the AM TUNER (AM>PRESETS>ADD PRESETS>REMOVE PRESETS>AUTO STORE>LOCAL).

PRESETS

Press the encoder button to access the PRESETS list. Using this feature allows you to see what PRESETS are saved on the unit.

ADD PRESETS

Press the encoder button on the ADD PRESETS option. You will need to be on both the station and PRESET group you want to add first (AM1>AM2). Using this feature allows you to save stations to the unit. Once selected, use the rotary encoder to select the PRESET number (1-6) you want the station saved to.

REMOVE PRESETS

Press the encoder button on the REMOVE PRESETS option. You will need to be under the PRESET group you want to adjust first (AM1>AM2). Using this feature allows you to remove saved stations on the unit. Once selected, use the rotary encoder to select the PRESET number (1-6) of the station you want removed.

AM

Press the encoder button to access the FM PRESET options (AM1>AM2). Using this feature allows you to have separate tuner preset groups to choose from. Use the rotary encoder button to scroll through the TUNER groups and press to select the group.

AUTO STORE

Press the encoder button to access the AUTO STORE function. You will need to be under the PRESET group you want to adjust first (AM1>AM2). This feature automatically stores presets on the unit. It will stop when presets 1-6 are set. Select the next PRESET group and repeat to fill next set.

LOCAL

Press the encoder button to access the LOCAL options. Once selected, use the rotary encoder to select ON or OFF. The local option tunes to nearby radio stations with sufficiently strong signals for good reception. In areas where reception is poor, switching to distance tuning enables the unit to tune in to more distant stations. Distance tuning is the default.

To skip a track forward, press the FWD button. To skip a track backwards, press the REV button.

To access USB specific settings, press the MENU button for the list of settings (BROWSER>REPEAT>SHUFFLE). Use the encoder to select the option to change.

BROWSER

Press the encoder button to access the BROWSER options (PLAY LISTS>ARTISTS>ALBUMS>GENRES>SONGS>COMPOSERS>AUDIO BOOKS>PODCASTS). Using this feature allows you to search for tracks or songs by different types of categories.

To page/down, use the track forward and track backwards buttons.

REPEAT

Press the encoder button to access the REPEAT feature options (OFF>ONE>ALL).

SHUFFLE

Press the encoder button to access the SHUFFLE feature options (OFF>ALL). This feature allows you to set your preference on shuffling tracks or songs.



AUX Operation

After your device is plugged into the source unit, this feature allows you to play music from your device. Select the AUX source option on the source unit and use your plugged in device to control song/track selection, PLAY/PAUSE and track skip FWD/REV.

Note: For use with USB or AUX input, an optional auxiliary input port (part# PAUX or PMX-USBP(USB only)) may be mounted in the fairing or a storage pocket.

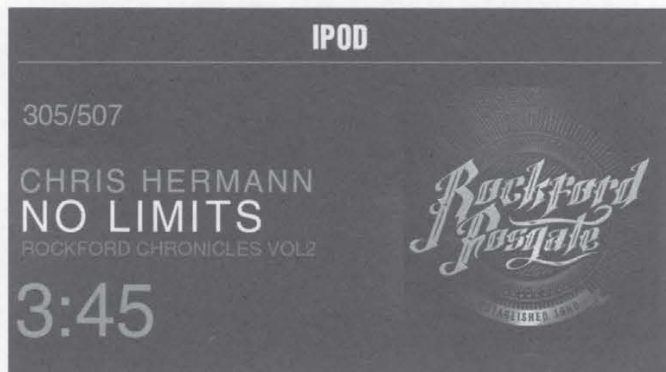

USB (iPod) Operation

After your device is connected to the source unit, this feature allows you to control playback from your device directly from the source unit. Select the USB source option on the source unit.

To play or pause a song, press the PLAY/PAUSE button.



Bluetooth® Operation

After your device is paired to the source unit, this feature allows you to control playback from your device directly from the source unit. Select the BLUETOOTH source option on the source unit.

To play or pause a song, press the PLAY/PAUSE button.

To skip a track forward, press the FWD button. To skip a track backwards, press the REV button.

To access BLUETOOTH specific settings, press the MENU button for the list of settings (BROWSER>REPEAT>SHUFFLE). Use the encoder to select the option to change.

BROWSER

Press the encoder button to access the BROWSER options (PLAY LISTS>ARTISTS>ALBUMS>GENRES>SONGS>COMPOSERS>AUDIO BOOKS>PODCASTS). Using this feature allows you to search for tracks or songs by different types of categories.

REPEAT

Press the encoder button to access the REPEAT feature options (OFF>ONE>ALL). This feature allows you to set your preference on the amount of times a track or song will repeat.

SHUFFLE

Press the encoder button to access the SHUFFLE feature options (OFF>ALL). This feature allows you to set your preference on shuffling tracks or songs.

NOTE: When the device is initially paired, the volume on the device will be roughly at half volume. You will need to turn the volume all the way up on the connected device prior to level setting. The device will remain at maximum volume after initially setting and when it re-pairs to the source unit.

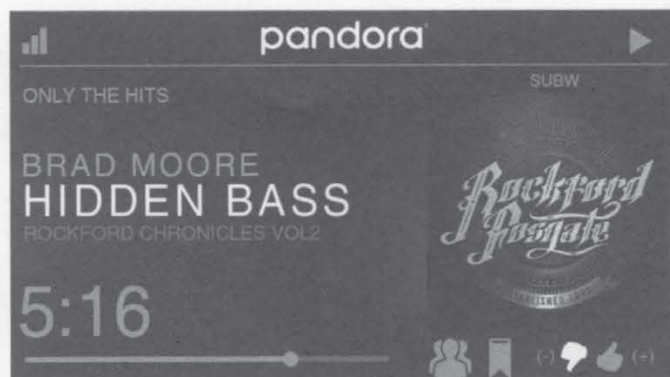

Pandora®

This feature allows you to control the Pandora® app from the source unit directly (Android users will have to use Bluetooth only, iOS users can use both USB and Bluetooth). You will need to start the Pandora® app on your device first, then select the Pandora® source option on the source unit. To use the “Thumbs Up” feature, press and hold the SUB+ button. To use the “Thumbs down” feature, press and hold the SUB - button.

To play or pause a song, press the PLAY/PAUSE button.

To skip a track forward, press the FWD button.

To access Pandora® specific settings, press the MENU button for the list of settings (STATIONS>BOOKMARKS>STATIONS MANAGE). Use the encoder to select the option to change.

STATIONS

To adjust, press the encoder button to access. Rotate the encoder button to select your options (SHUFFLE>SORT DATE/A-Z>STATIONS). Selecting the SHUFFLE option will shuffle your stations and selecting the SORT feature will sort your stations by date added or alphabetically. You can also select your saved stations directly from this list.

BOOKMARKS

To BOOKMARK an artist or track that is playing, press the encoder button to display your BOOKMARK options (ARTIST>TRACK). Select the option you wish to use for bookmarking.

Pandora, the Pandora logo, and the Pandora trade dress are trademarks or registered trademarks of Pandora Media, LLC. Used with permission. Pandora is only available in certain countries. Please visit <http://www.pandora.com/legal> for more information.

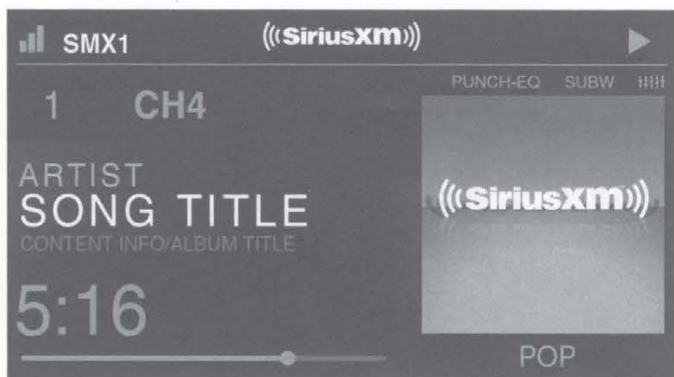

SiriusXM® (US and Canada only)

Only SiriusXM® brings you more of what you love to listen to, all in one place. Get over 140 channels, including commercial-free music plus the best sports, news, talk, comedy and entertainment. Welcome to the world of satellite radio. A SiriusXM Connect Tuner and Subscription are required. For more information, visit www.siriusxm.com

ACTIVATING YOUR SiriusXM SUBSCRIPTION

After installing your SiriusXM Connect Tuner and antenna, power on your source unit and select SiriusXM mode. You should be able to hear the SiriusXM Preview channel on Channel 1. If you cannot hear the preview channels, please check the installation instructions to make sure your SiriusXM Connect Twuner is properly installed.

After you can hear the Preview channel, tune to Channel 0 to find the Radio ID of your tuner. In addition, the Radio ID is located on the bottom of the SiriusXM Connect Tuner and its packaging. You will need this number to activate your subscription. Write the number down for reference.

Note: the SiriusXM Radio ID does not include the letters I, O, S or F.

In the USA, you can activate online or by calling SiriusXM Listener care:

- Visit www.siriusxm.com/activatenow
- Call SiriusXM Listener Care at 1-866-635-2349

For Canadian Subscriptions, please contact:

- Visit www.siriusxm.ca/activatexm
- Call XM Customer Care at 1-877-438-9677

As part of the activation process, the SiriusXM satellites will send an activation message to your tuner. When your radio detects that the tuner has received the activation message, your radio will display: "Subscription Updated". Once subscribed, you can tune to channels in your subscription plan. Note, the activation process usually takes 10 to 15 minutes, but may take up to an hour. Your radio will need to be powered on and receiving the SiriusXM signal to receive the activation message.

SETTINGS

To access the SiriusXM SETTINGS, press the MENU when using the SiriusXM source. This will give you access to the settings specific to SiriusXM (SXM>PRESETS>ADD PRESETS>REMOVE PRESETS>CHANNELS>CATEGORY).

SiriusXM PRESET BANDS (SXM)

Press the encoder button to access the SiriusXM PRESET options (SXM1>SXM2>SXM3). Using this feature allows you to have separate satellite preset groups to choose from. Use the FWD and REV buttons to scroll through the TUNER groups.

PRESETS

Press the encoder button to access the PRESETS list. Using this feature allows you to see what PRESETS are saved on the unit.

ADD PRESETS

Press the encoder button on the ADD PRESETS option. You will need to be on both the channel and PRESET group you want to add first (SXM1>SXM2>SXM3). Using this feature allows you to save channels to the unit. Once selected, use the rotary encoder to select the PRESET number (1-6) you want the channel saved to.

REMOVE PRESETS

Press the encoder button on the REMOVE PRESETS option. You will need to be under the PRESET group you want to adjust first (SXM1>SXM2>SXM3). Using this feature allows you to remove saved channels on the unit. Once selected, use the rotary encoder to select the PRESET number (1-6) of the channel you want removed.

CHANNEL

Press the encoder button on the CHANNEL option to select this feature. This feature displays a complete listing of channels.

CATEGORY

Press the encoder button on the CATEGORY option to select this feature. This feature allows you to search channels based on their CATEGORY type.

DIRECT TUNING

Press the encoder button on the DIRECT TUNING option to select this feature. This feature allows you to directly tune to a channel if you already know the channel number. Rotate the encoder until you reach the desired numeral and press to enter your selection. Repeat until the channel number is completed.

PARENTAL CONTROLS

Press the encoder button on the PARENTAL CONTROL option to select this feature. This feature allows you to easily lock and unlock channels with mature content. To turn this feature on, press the encoder on PARENTAL CONTROLS to select. You will be asked to enter a code to activate it. Enter "1111" for your code. Once the code is entered correctly, this will give you access to the PARENTAL CONTROL features (LOCK CHANNELS>CHANGE MY CODE). Use the encoder knob to scroll through the options and press to select.

LOCK CHANNELS

Press the encoder button on the LOCK CHANNELS option to select this feature. This feature allows you to select certain channels to be locked out for listening. When trying to listen to locked channels, you will need to enter the correct access code to listen to them. Use the rotary encoder to input code.

CHANGE MY CODE

Press the encoder button on the CHANGE MY CODE option to reset the PARENTAL CONTROL access code. Use the rotary encoder to input the code.

Phone Control		PMX-HD9813 Control									
		USB/MP3/WMA		AUX-IN		iPhone/iPod		BT Audio		SiriusXM	
Short Press	Long Press	Short Press	Long Press	Short Press	Long Press	Short Press	Long Press	Short Press	Long Press	Short Press	Long Press
Volume +	Ramp Volume +	Volume +	Ramp Volume +	Volume +	Ramp Volume +	Volume +	Ramp Volume +	Volume +	Ramp Volume +	Volume +	Ramp Volume +
Volume -	Ramp Volume -	Volume -	Ramp Volume -	Volume -	Ramp Volume -	Volume -	Ramp Volume -	Volume -	Ramp Volume -	Volume -	Ramp Volume -
Play / Pause	Hands Free *	Play / Pause (Enter)		MUTE (Enter)		Play / Pause (Enter)		MUTE (Enter)		MUTE (Enter)	
Previous	Rewind	Previous	Rewind	Previous	Rewind	Previous	Rewind	Previous	Rewind	Previous	Rewind
Next	Fast Forward	Next	Fast Forward	Next	Fast Forward	Next	Fast Forward	Next	Fast Forward	Next	Fast Forward
Call Answer * / Call Hang Up *	Call Reject * / Siri *	SRC / Power On	Power Off	SRC / Power On	Power Off	SRC / Power On	Power Off	SRC / Power On	Power Off	SRC / Power On	Power Off

* iOS Only

Troubleshooting

Symptom / Advisory	Diagnosis	Remedy
Basic		
Source unit does not turn on.	Blown fuse	Check fuse of the unit, replace with correct rating.
	Motorcycle's ignition is off	If connected following the instructions, the unit will not operate with ignition off.
	Voltage applied to Red wire is not between 10.5 & 16 volts or there is no voltage present	Check battery, connections and fuses and repair or replace as necessary. If voltage is above +16 volts, have the electrical system inspected by an authorized service center.
	Unit is not properly grounded	Check wiring and repair as necessary.
Radio Tuner		
Tuner fails to tune any stations	No antenna or disconnected or open connection in cable	Check all connections and repair as necessary.
Unable to tune stations in seek mode	You are in a weak signal area	Make sure the tuner LOC mode is off. Add optional antenna (part # PMX-ANT)
USB Devices		
USB device cannot be inserted	The USB device has been inserted in the wrong direction	Reversing the connection direction of the USB device, try reinserting.
	The USB device connector is broken	Replace with a new USB device.
USB device is not recognized	The USB device is damaged	Disconnect USB device and reconnect. If the device is still not recognized, try replacing with a different USB device. USB does not work with Android devices.
	Connectors are loose	
No sound heard with the display "No File" shown	No MP3/WMA files are stored on the USB device	Store these files properly on the USB device. USB does not work with Android devices.
Sound skips or is noisy	MP3/WMA files are not created properly	Use MP3/WMA files that are encoded correctly.
AUX		
MP3 is not playing back	Writing error occurred. The MP3 format is not compatible.	Make sure MP3 has been written in a supported format
Bluetooth		
Bluetooth source volume is lower than other sources	Bluetooth from device is not at maximum volume	Turn the volume on the device to maximum level

SiriusXM		
Check Antenna	The radio has detected a fault with the SiriusXM antenna. The antenna cable may be either disconnected or damaged.	<p>Verify that the antenna cable is connected to the SiriusXM Connect Tuner</p> <p>Inspect the antenna cable for damage and kinks. Replace the antenna if the cable is damaged.</p> <p>SiriusXM products are available at your local car audio retailer or online at www.shop.siriusxm.com</p>
Check Tuner	The radio is having difficulty communicating with the SiriusXM Connect Tuner. The tuner may be disconnected or damaged.	Verify that the SiriusXM Connect Tuner cable is securely connected to the radio
No Signal	The SiriusXM Connect Tuner is having difficulty receiving the SiriusXM satellite signal.	<p>Verify that your vehicle is outdoors with a clear view of the sky.</p> <p>Verify that the SiriusXM magnetic mount antenna is mounted on a metal surface on the outside of the vehicle.</p> <p>Move the SiriusXM antenna away from any obstructions.</p> <p>Inspect the antenna cable for damage and kinks.</p> <p>Consult the SiriusXM Connect Tuner installation manual for more information on antenna installation. Replace the antenna if the cable is damaged. SiriusXM products are available at your local car audio retailer or online at www.shop.siriusxm.com.</p>
Subscription Updated	The radio has detected a change in your SiriusXM subscription status. Press the encoder button to clear the message.	Visit www.siriusxm.com or call 866-635-2349 in the USA or 877-438-9677 in Canada if you have questions about your subscription.
Channel Not Available	The channel that you have requested is not a valid SiriusXM channel or the channel that you were listening to is no longer available. You may also see this message briefly when first connecting a new SiriusXM Connect Tuner.	Visit www.siriusxm.com for more information about the SiriusXM channel lineup.
Channel Not Subscribed	The channel that you have requested is not included in your SiriusXM subscription package or the channel that you were listening to is no longer included in your SiriusXM subscription package.	Visit www.siriusxm.com or call 866-635-2349 in the USA or 877-438-9677 in Canada if you have questions about your subscription package or would like to subscribe to this channel.
Channel Locked	The channel that you have requested is Locked by the radio Parental Control feature. See page 10 for more information on the Parental Control feature and how to access locked channels.	

Rockford Corporation offers a limited warranty on Rockford Fosgate products on the following terms:

Length of Warranty

POWER Amplifiers – 2 Years
BMW® Direct Fit Speakers – 2 Years
PUNCH® & PRIME® Amplifiers – 1 Year
Speakers, Signal Processors, Accessories and Capacitors – 1 Year
All marine, motorcycle, motorsport products - 2 Years
Any Factory Refurbished Product – 90 Days (receipt required)

What is Covered

This warranty applies only to Rockford Fosgate products sold to consumers by authorized Rockford Fosgate dealers in the United States of America. Products purchased by consumers from an Authorized Rockford Fosgate Dealer in another country are covered only by that country's Distributor and not by Rockford Corporation.

Who is Covered

This warranty covers only the original purchaser of Rockford product purchased from an authorized Rockford Fosgate dealer in the United States. In order to receive service, the purchaser must provide Rockford with a copy of the receipt stating the customer name, dealer name, product purchased and date of purchase.

Products found to be defective during the warranty period will be repaired or replaced (with a product deemed to be equivalent) at Rockford's discretion.

What is Not Covered

1. Damage caused by accident, abuse, improper installation, operations, theft, water (on non-Element Ready products).
2. Any cost or expense related to the removal or reinstallation of product.
3. Service performed by anyone other than Rockford or an authorized Rockford Fosgate service center.
4. Any product which has had the serial number defaced, altered, or removed.
5. Subsequent damage to other components.
6. Any product purchased outside the U.S.
7. Any product not purchased from an authorized Rockford Fosgate dealer. Refer to rockfordfosgate.com dealer locator for more detail.

Limit on Implied Warranties

Any implied warranties including warranties of fitness for use and merchantability are limited in duration to the period of the express warranty set forth above. Some states do not allow limitations on the length of an implied warranty, so this limitation may not apply. No person is authorized to assume for Rockford Fosgate any other liability in connection with the sale of the product.

How to Obtain Service

Please call 1-800-669-9899 for Rockford Customer Service. You must obtain an RA# (Return Authorization number) to return any product to Rockford Fosgate. You are responsible for shipment of product to Rockford.

EU Warranty

This product meets the current EU warranty requirements, see your Authorized dealer for details.

— Installation assistance available at: —

RFTECH

— www.rockfordfosgate.com/rftech —

062819

1230-70243-01-D

600 South Rockford Drive • Tempe, Arizona 85281 United States
Direct: (480) 967-3565 • Toll Free: (800) 669-9899

rockfordfosgate.com

Installation assistance available at:

RFTECH

www.rockfordfosgate.com/rftech

P O W E R

1998-2013 HARLEY-DAVIDSON®
SPEAKERS

TMS6RG • TMS6SG
TMS5

Printed in China

1230-59287-01-A

041416

600 South Rockford Drive • Tempe, Arizona 85281 United States
Direct: (480) 967-3565 • Toll Free: (800) 669-9899

ROCKFORDFOSGATE.COM



Serial Number: _____ Date of Purchase: _____



Installation & Operation

Introduction

Dear Customer,

Congratulations on your purchase of the world's finest brand of audio products. At Rockford Fosgate we are fanatics about musical reproduction at its best, and we are pleased you chose our product. Through years of engineering expertise, hand craftsmanship and critical testing procedures, we have created a wide range of products that reproduce music with all the clarity and richness you deserve.

For maximum performance we recommend you have your new Rockford Fosgate product installed by an Authorized Rockford Fosgate Dealer, as we provide specialized training through Rockford Technical Training Institute (RTTI). Please read your warranty and retain your receipt and original carton for possible future use.

Great product and competent installations are only a piece of the puzzle when it comes to your system. Make sure that your installer is using 100% authentic installation accessories from Rockford Fosgate in your installation. Rockford Fosgate has everything from RCA cables and speaker wire to power wire and battery connectors. Insist on it! After all, your new system deserves nothing but the best.

To add the finishing touch to your new Rockford Fosgate image, order your Rockford accessories, which include everything from T-shirts to hats.

Visit our web site for the latest information on all Rockford products;

www.rockfordfosgate.com

or, in the U.S. call 1-800-669-9899 or FAX 1-800-398-3985. For all other countries, call +001-480-967-3565 or FAX +001-480-966-3983.

Table of Contents

2	Introduction
3-6	Specifications
7	Installation Considerations
8-11	Installation
12	Français
13	Español
14	Deutsch
15	Italiano
16	Warranty

If, after reading your manual, you still have questions regarding this product, we recommend that you see your Rockford Fosgate dealer. If you need further assistance, you can call us direct at **1-800-669-9899**. Be sure to have your serial number, model number and date of purchase available when you call.

PRACTICE SAFE SOUND

Continuous exposure to sound pressure levels over 100dB may cause permanent hearing loss. High powered auto sound systems may produce sound pressure levels well over 130dB. Use common sense and practice safe sound.

PRATIQUEZ UNE ÉCOUTE SANS RISQUES

Une exposition continue à des niveaux de pression acoustique supérieurs à 100 dB peut causer une perte d'acuité auditive permanente. Les systèmes audio de forte puissance pour auto peuvent produire des niveaux de pression acoustique bien au-delà de 130 dB. Faites preuve de bon sens et pratiquez une écoute sans risques

PRACTIQUE EL SONIDO SEGURO

El contacto continuo con niveles de presión de sonido superiores a 100 dB puede causar la pérdida permanente de la audición. Los sistemas de sonido de alta potencia para automóviles pueden producir niveles de presión de sonido superiores a los 130 dB. Aplique el sentido común y practique el sonido seguro.

PRAKTIZIEREN SIE SICHEREN SOUND

Fortgesetzte Geräuschdruckpegel von über 100 dB können beim Menschen zu permanentem Hörverlust führen. Leistungsstarke Autosoundsysteme können Geräuschdruckpegel erzeugen, die weit über 130 dB liegen. Bitte wenden Sie gesunden Menschenverstand an und praktizieren Sie sicheren Sound.

OSSERVATE LE REGOLE DEL SUONO SENZA PERICOLI

La costante esposizione a livelli di pressione acustica al di sopra dei 100dB possono causare la perdita permanente dell'udito. I sistemi audio ad alta potenza possono produrre livelli di pressione acustica ben superiori ai 130dB. Si consiglia il buon senso e l'osservanza delle regole del suono senza pericoli

Safety

This symbol with "WARNING" is intended to alert the user to the presence of important instructions. Failure to heed the instructions will result in severe injury or death.



This symbol with "CAUTION" is intended to alert the user to the presence of important instructions. Failure to heed the instructions can result in injury or unit damage.



- To prevent injury and damage to the unit, please read and follow the instructions in this manual. We want you to enjoy this system, not get a headache.
- If you feel unsure about installing this system yourself, have it installed by a qualified Rockford Fosgate technician.
- Before installation, disconnect the battery negative (-) terminal to prevent damage to the unit, fire and/or possible injury.

Model	TMS6RG	TMS6SG	TMS5
Nominal Diameter - inch (mm)	6.5 (165)	6.5 (165)	5.25 (133)
Description	2-Way	2-Way	2-Way
Nominal Impedance (Ohms)	4Ω	4Ω	4Ω
Frequency Response (Hz)	65-20kHz	65-20kHz	65-20kHz
Voice Coil Diameter - inch (mm)	1.4 (35.6)	1.4 (35.6)	1.4 (35.6)
Power Handling - Watts (RMS/Peak)	75/150	75/150	65/130
Fs - Free Air Resonance (Hz)	86.5	86.5	86.5
Qts	0.52	0.52	0.58
Vas - cu. ft. (Liter)	0.198 (5.6)	0.198 (5.6)	0.191 (5.4)
Sensitivity (1W/1M)	91dB	91dB	90dB
Sensitivity (2.83V/1M)	94dB	94dB	93dB
Xmax - inch (mm)	0.19 (3.0)	0.19 (3.0)	0.19 (3.0)
Mounting Diameter	5.0 (128)	5.0 (128)	4.6 (116)
Mounting Depth	2.1 (53)	2.1 (53)	2.0 (52)
Grille/Trim Ring	YES	YES	YES

See page 4-6 for additional dimensions



CEA 2031

Power handling on Rockford Fosgate speakers conform to CEA-2031 industry standards. This means your speaker has the capacity to handle power under continuous demand, not instantaneous power handling that over time can damage voice coils.



VERIFIED WITH KLIPPEL

To adorn the 'Verified with Klippel' mark, the qualifying company's loudspeaker engineering personnel must be trained and certified by Klippel prior to using the three separate Klippel systems to design, develop and test. Rockford Fosgate has made the investment in Klippel to deliver the best possible speakers and subwoofers to their customers.

Specifications

TMS6RG

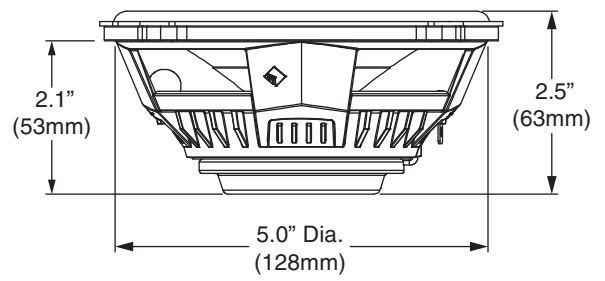
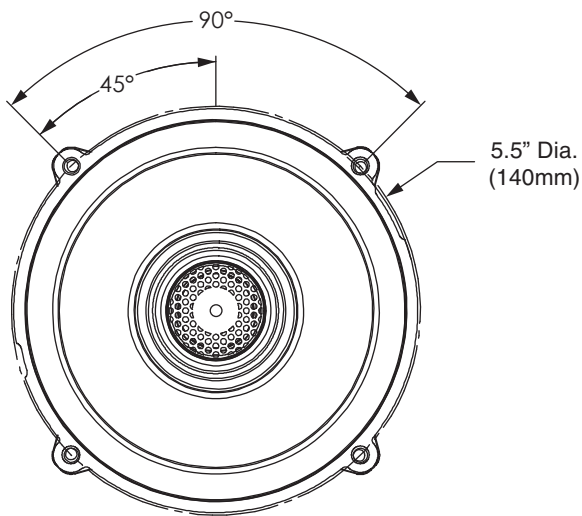
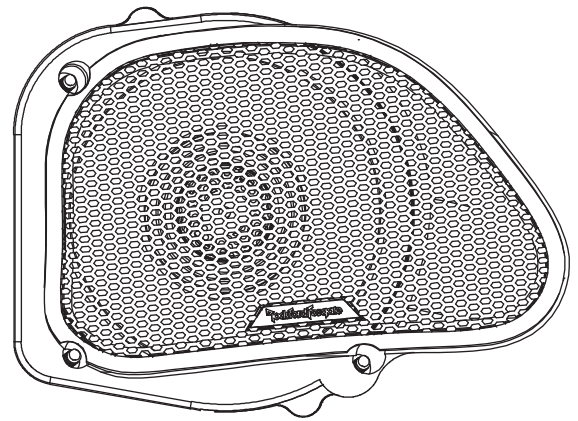
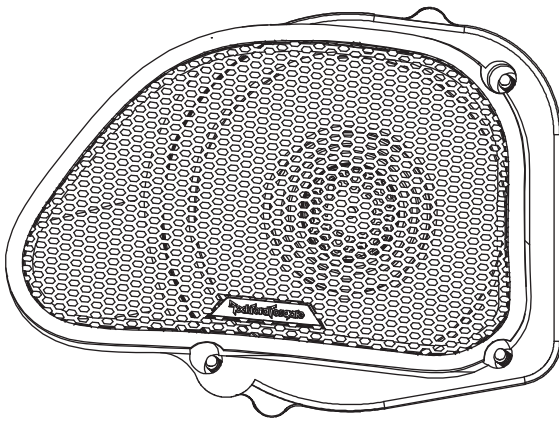
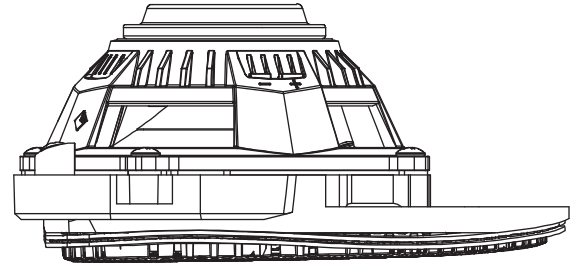
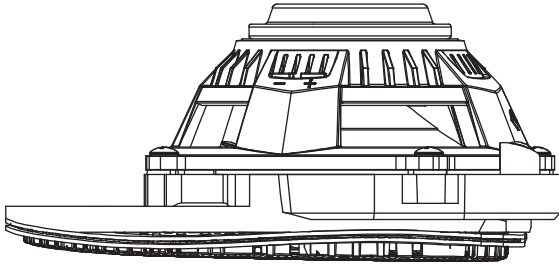

TMS6SG

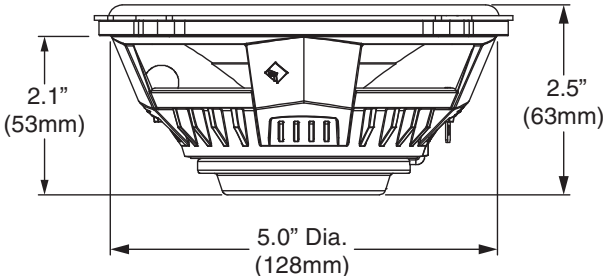
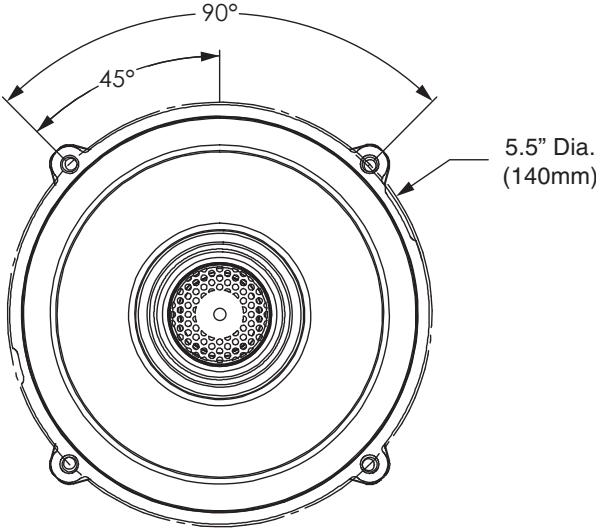
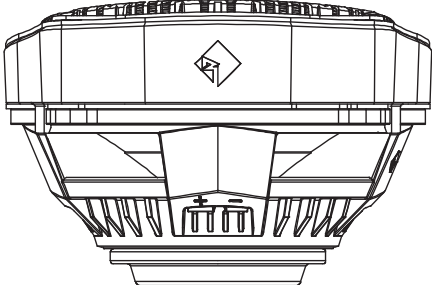
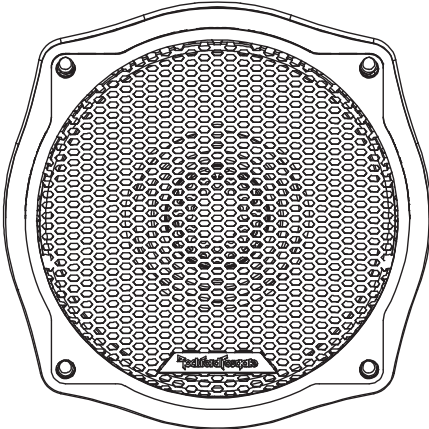

Specifications

TMS5

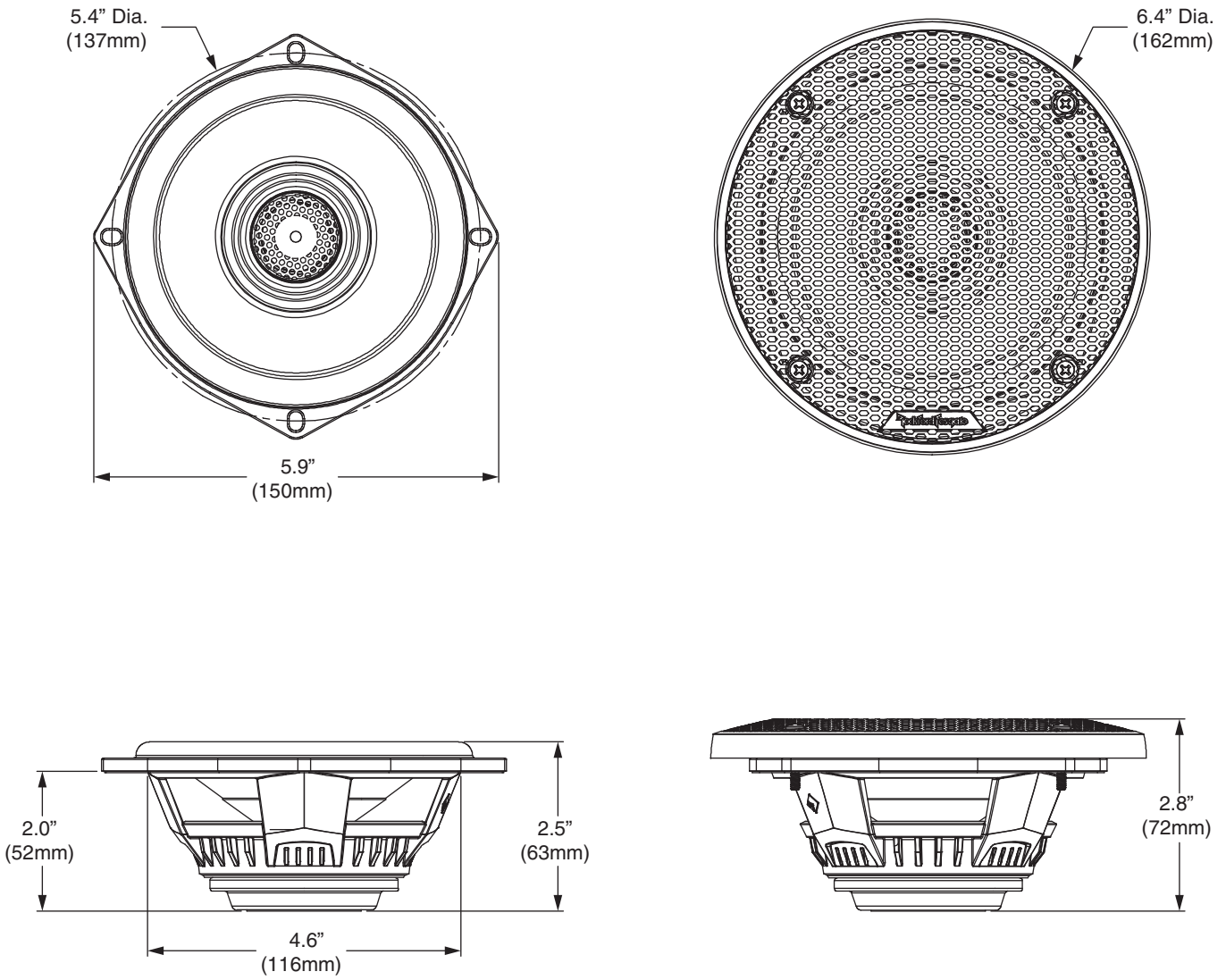

Contents

- (1) Pair of 2-Way Speakers with Grilles
- Installation & Operation Manual
- Hardware Pack

Installation Tools

The following is a list of suggested tools needed for installation:

- Wrenches / Sockets - 7/16", 3/8", 1/2", 10mm
- Allen Wrench - 1/8", 5/32"
- Torx - T10, T25
- #2 Phillips Screw Driver

Installation Considerations

This section focuses on some considerations for installing your motorcycle replacement speakers. This manual will illustrate the installation of two different fairing styles and Tour-Pak offered by Harley-Davidson® from the production years ranging from 1998 to 2013. (Ultra Classic®, Electra Glide®, Street Glide®, Tri Glide®, Road Glide® and Road Glide Ultra®.)

If you feel unsure about installing this system yourself, have it installed by a qualified technician.



CAUTION

Before installation, disconnect the battery negative (-) terminal to prevent damage to the unit, fire and/or possible injury.



CAUTION

Before beginning any installation, follow these simple rules:

- Be sure to carefully read and understand the instructions before attempting to install these motorcycle speakers.
- Consult your motorcycle's service manual for model specific information. Models may differ from year to year depending on factory options and aftermarket accessories added.
- These motorcycle speakers are a complete replacement to the factory (OEM) speaker setup.
- With the addition of an amplifier, be sure that your current charging system is in proper working order.
- Utilize a blanket or fender cover to protect the front fender from tools or any other item that may be accidentally be dropped while removing the fairing.
- Visit rockfordfosgate.com for more comprehensive installation videos and product information.

Installation

Front Speakers for Ultra Classic®, Electra Glide®, Street Glide® and Tri Glide® models.



Step 1 - Fairing Removal

To begin with, remove the top screws below the windshield to remove the windshield.



Once you have the windshield set aside, remove the remaining screws on the inside of the fairing. This will allow you to remove the front fairing.



You will need to disconnect the harness from the headlight to completely take the fairing off of the motorcycle.

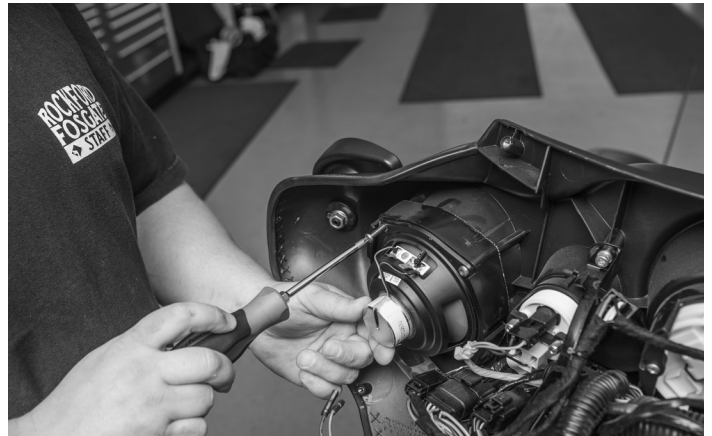

Step 2 - Speaker Removal

After the fairing is removed, unplug the wires from both speaker terminals. Remove the screws that secure the factory speaker and grille to the fairing.

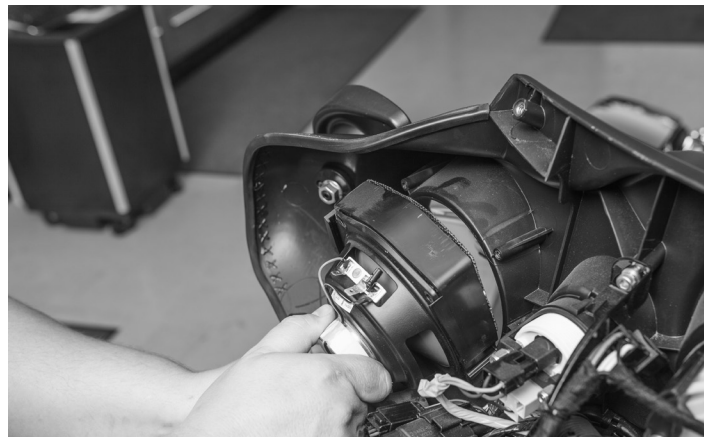

Remove each speaker and grille from the fairing.

NOTE: Be sure to keep track of the wires that are plugged into the clutch and brake side speakers.



Step 3 - Speaker Installation

Insert the new Rockford speaker and grille assembly into the fairing opening with the wire terminals facing up. Use the included screws to securely mount the speakers to the fairing.

NOTE: There are two screw lengths included in the hardware pack. For this fairing application, use the longer screws on the top two mounting holes of the speaker.



Connect the speakers by sliding the speaker wire connectors over the speaker terminals

NOTE: The smaller terminal is the positive (+) and the larger terminal is the negative (-).

Front Speakers for Road Glide® and Road Glide Ultra® models.



Step 1 - Fairing Removal

Leaving the windshield in place, remove the six inner fairing screws.



After the screws are removed, use your socket or ratcheting wrench to unbolt the turn signal brackets.

NOTE: Some turn signal brackets stay attached and some can be completely removed. This varies depending on aftermarket and factory accessory styles

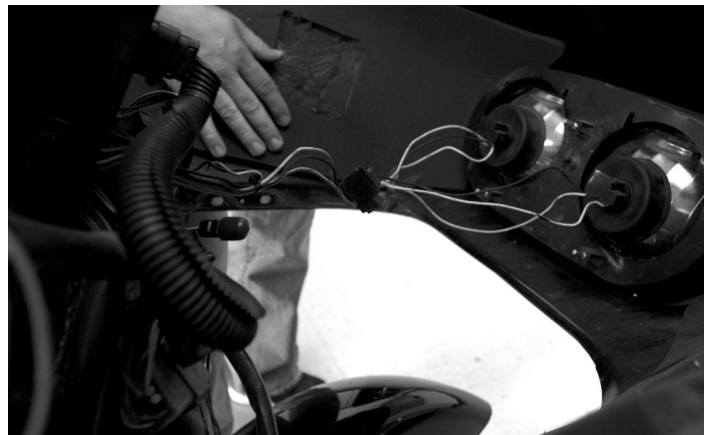

Pull the fairing toward the front of the bike and up to release it from the fairing mounts. Unplug headlight harness and set fairing aside.



Step 2 - Speaker Removal

After the fairing is removed, unplug the wires from both speaker terminals. Remove the screws that secure the factory speaker from the fairing.

Installation



Step 3 - Speaker Installation

Insert the new Rockford speaker and grille assembly onto the speaker opening on the backside of the fairing. Use the included screws to securely mount the speakers



Connect the speakers by sliding the speaker wire connector over the speaker terminals

NOTE: The smaller terminal is the positive (+) and the larger terminal is the negative (-).

Rear Speakers for Tour-Pak models.



Step 1 - Rear Speaker Removal

Unscrew the speaker grilles from the rear pods and remove factory speaker. Disconnect the factory wiring from the speaker terminal and remove speaker.



Step 2 - Rear Speaker Installation

Connect the speakers by sliding the speaker wire connector over the speaker terminals

NOTE: The smaller terminal is the positive (+) and the larger terminal is the negative (-).



Insert the new Rockford speaker into the speaker pod.



Place the grille over the speaker and attach with the included screws to mount to the pod.

Warranty

Rockford Corporation offers a limited warranty on Rockford Fosgate products on the following terms:

Length of Warranty

POWER Amplifiers – 2 Years
BMW® Direct Fit Speakers – 2 Years
Source Units – 1 Year
All other products – 1 Year
Any Factory Refurbished Product – 90 days (receipt required)

What is Covered

This warranty applies only to Rockford Fosgate products sold to consumers by Authorized Rockford Fosgate Dealers in the United States of America or its possessions. Product purchased by consumers from an Authorized Rockford Fosgate Dealer in another country are covered only by that country's Distributor and not by Rockford Corporation.

Who is Covered

This warranty covers only the original purchaser of Rockford product purchased from an Authorized Rockford Fosgate Dealer in the United States. In order to receive service, the purchaser must provide Rockford with a copy of the receipt stating the customer name, dealer name, product purchased and date of purchase.

Products found to be defective during the warranty period will be repaired or replaced (with a product deemed to be equivalent) at Rockford's discretion.

What is Not Covered

1. Damage caused by accident, abuse, improper operations, water, theft, shipping.
2. Any cost or expense related to the removal or reinstallation of product.
3. Service performed by anyone other than Rockford or an Authorized Rockford Fosgate Service Center.
4. Any product which has had the serial number defaced, altered, or removed.
5. Subsequent damage to other components.
6. Any product purchased outside the U.S.
7. Any product not purchased from an Authorized Rockford Fosgate Dealer.

Limit on Implied Warranties

Any implied warranties including warranties of fitness for use and merchantability are limited in duration to the period of the express warranty set forth above. Some states do not allow limitations on the length of an implied warranty, so this limitation may not apply. No person is authorized to assume for Rockford Fosgate any other liability in connection with the sale of the product.

How to Obtain Service

Contact the Authorized Rockford Fosgate Dealer you purchased this product from. If you need further assistance, call 1-800-669-9899 for Rockford Customer Service. You must obtain an RA# (Return Authorization number) to return any product to Rockford Fosgate. You are responsible for shipment of product to Rockford.

EU Warranty

This product meets the current EU warranty requirements, see your Authorized dealer for details.