

Infinity Kappa five - Owner's Manual

EN

Infinity Kappa five - Mode D'emploi

FR

Infinity Kappa five - Manual de Propietario

ES

Infinity Kappa five - Manual do Proprietário

PT

Infinity Kappa five - 사용자 설명서

KO

Infinity Kappa five - 用户手册

CHS

Infinity Kappa five - 擁有者手冊

CHT

Infinity Kappa five - Buku panduan pemilik

ID

THANK YOU FOR YOUR PURCHASE . . .

Your product has been designed to provide you the performance and ease of operation you expect from Infinity. Take time to read this manual before operating or installing your amplifier. Keep it in your glove compartment along with the owner's manual for your car. Put your amplifier sales receipt with other important documents in order to expedite warranty service if needed. This manual describes general installation guidelines and operation instructions. Please note that proper installation of mobile audio components requires qualified experience with mechanical and electrical procedures. If you do not have the knowledge and tools to perform this installation, we strongly recommend consulting an authorized Infinity dealer about your installation options.

What's in the box

1x amplifier	1x E.A.R.L ground terminal
6x speaker-level input adapter	3x self-tapping screws
4x mounting screws	1x remote bass controller and cable
3x spare fuses	1x power terminal block
	1x owner's manual

INSTALLATION AND WIRING

IMPORTANT: Disconnect the vehicle's negative (-) battery terminal before beginning the installation.

- Wear protective eyewear when using tools.
- Choose a safe mounting location, away from moisture. Check clearances on both sides of the location. Be sure that screws will not puncture brake or fuel lines or wiring harnesses, and that wire routing will not interfere with vehicle operation. Use caution when drilling or cutting.
- When making electrical connections, make sure they are secure and properly insulated.
- To keep the amplifier cool, choose a location that provides enough air circulation, such as under a seat or in the trunk.
- Do not mount the amplifier with the heat sink facing downward, as this interferes with cooling.
- Mount the amplifier so that it will not be damaged by the feet of passengers or shifting cargo in the trunk, and so that it remains dry.
- Using the amplifier as a template, mark the locations of the holes on the mounting surface.
- Drill pilot holes in the mounting surface.
- Attach the amplifier to the mounting surface with the included screws.

NOTE: You may find it more convenient to make all of the connections to the amplifier before you permanently mount it.

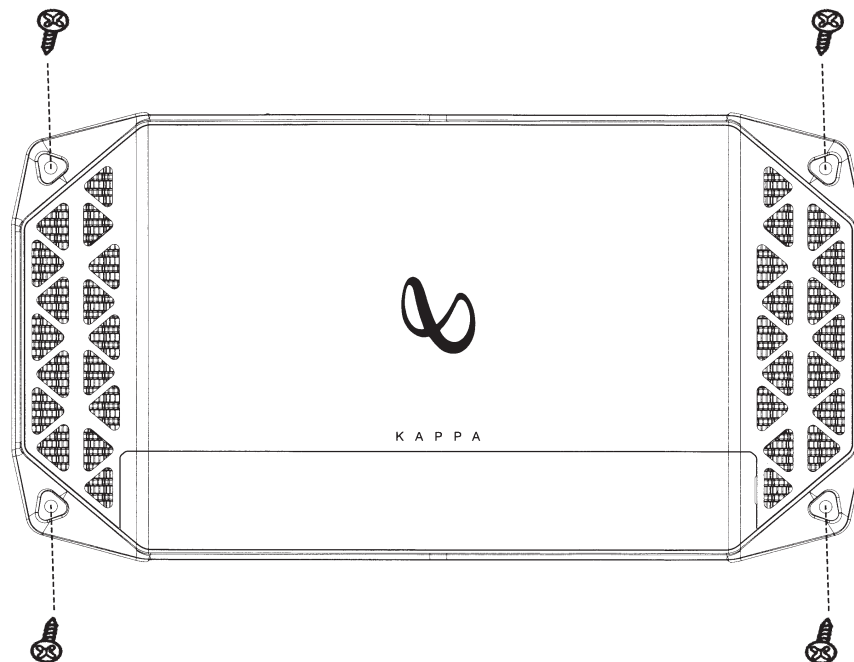

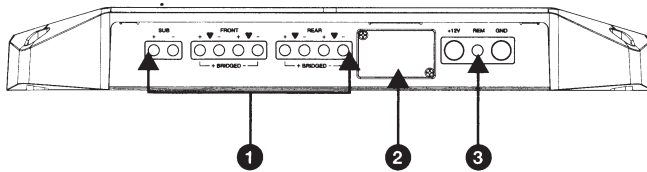

1 Speaker Output Connectors

Connect the speakers to these terminals, observing proper polarity: connect each speaker's positive (+) lead to the appropriate positive (+) terminal, and negative (-) lead to the appropriate negative (-) terminal.

5-channel operation: Connect the front left speaker to the front L+ and L- terminals, and the front right speaker to the front R+ and R- terminals. Connect the rear left speaker to the rear L+ and L- terminals, and the rear right speaker to the rear R+ and R- terminals. Connect the subwoofer's + lead to the sub + terminal, and the - lead to the sub - terminal.

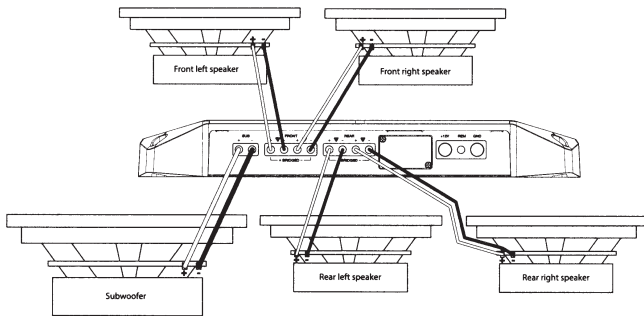

NOTE: Minimum speaker impedance is 2 ohms.

2 Fuses

Replace fuses only with the same amperage: 30A.

3 Power Input Connectors

- **Power:** Run 4-gauge power wire from the **+12V** input to the positive terminal of the vehicle's battery. Insert bare wire into the terminal on the amplifier, then tighten the setscrew with a Phillips screwdriver.
- Install an appropriate fuse holder and 100A fuse within 18" (457mm) of the battery. Install protective grommets when routing wires through the bulkhead or other sheet metal. Use larger-gauge wiring for longer runs.

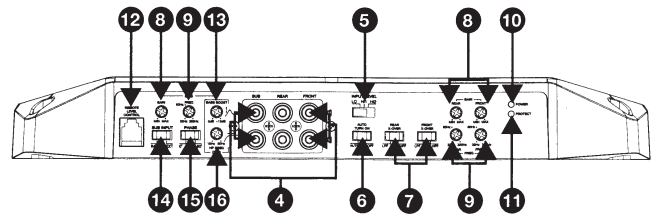

- **Remote:** The REM lead detects signal and instructs the amplifier to turn on/off. Connect a 20-gauge wire from the "Remote Out" lead of the source unit to the **REM** input between the +12V and GND inputs.

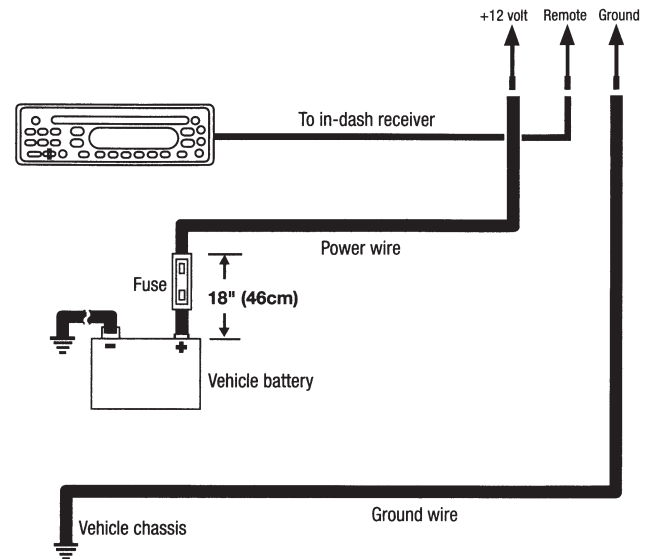

- **Ground:** Run a wire (the same gauge as the power wire) from the **GND** input to a factory bolt in the vehicle's chassis (see illustration below).
NOTE: Remove any paint from the chassis for best contact. If using a ring connector, place a star washer below the ring connector for a secure connection.
- For a more secure ground connection, use the included E.A.R.L. ground terminal. Crimp the open end of the terminal to the end of your ground wire, then place the terminal against bare chassis metal, and secure with the included self-tapping screws.
NOTE: Be sure to check below your desired ground location to ensure that the screws will not puncture brake lines, fuel lines, or wiring harnesses.

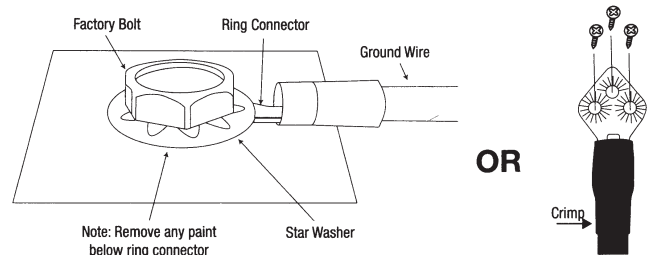

EN

4 Line-level inputs (RCA)

If your source unit offers preamp outputs, connect to the front and rear L and R, and subwoofer inputs using RCA patch cables.

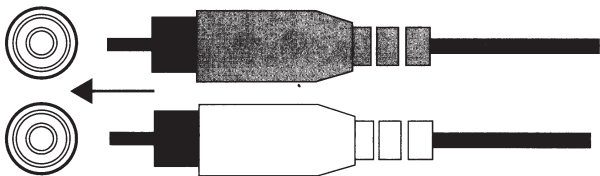

If your car audio system's head unit does not have line-level outputs, use the supplied bare wire-to-RCA adapters to connect the Kappa amplifier's inputs to either the front or the rear speaker outputs of your car audio system's head unit (splice crimps not included).

Use a small Phillips screwdriver to loosen the adapter's set screws and insert the speaker wires into the holes on the back of the adapter. Tighten the set screws to secure the wires.

Always connect the (+) speaker wire to the adapter's (+) terminal and the (-) speaker wire to the adapter's (-) terminal. When all wires are connected, plug the adapters into the Kappa amplifier's preamp inputs.

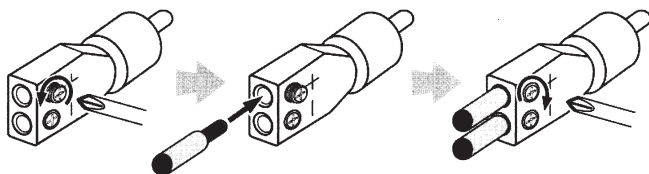

Loosen
Screws

Insert
Wires

Tighten
Screws

Important: Some factory audio system amplifiers include electronic filters that limit the amount of bass sent to the system's smaller speakers. This filtering will adversely affect the Kappa amplifier's performance. To get the most bass possible, splice the high-level wires into the factory speaker outputs that are connected to the system's largest speakers (the ones designed to reproduce the most bass).

5 Input level

Select LO if providing signal to the amplifier with line-level connections. Select HI1 or HI2 if using speaker-level connections.

Note: If you have connected your amplifier to factory speaker outputs and the audio fails to play, change the switch to "HI2". The "HI2" position includes a circuit designed to fool a factory audio system into "seeing" a speaker connected to its input.

Important: "HI2" should never be used when the amplifier is connected to a head unit's line-level (RCA) outputs.

INPUT LEVEL

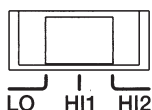

6 Auto turn-on selector

If your stereo has no "Remote Out" lead, slide the "AUTO TURN ON" switch to "ON". This will allow the amp to turn on when it detects speaker-level audio signal.

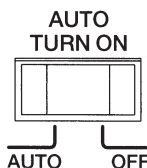

7 Crossover filter selectors (X-OVER)

You can choose the type of crossover filters for your front and rear channels.

- **LPF: Low pass.** Choose this setting if you're connecting a subwoofer(s), or want to provide a low-pass filter for separate mid-bass speakers.
- **FULL: Full range.** Choose this setting if you're connecting full-range speakers, and not using a subwoofer in your system.
- **HPF: High pass.** Choose this setting to prevent low bass from reaching midrange or full-range speakers when you're using a subwoofer in your system.

8 GAIN: Setting the input sensitivity

To match your amplifier's input sensitivity (gain) to your source unit's output level, we recommend the following procedure:

- Turn all input level controls counterclockwise to MIN (minimum).
- Play a dynamic music track through your source unit. Turn the source unit's volume control to the 3/4 position.
- Turn the front input level control dial clockwise towards MAX until you hear distortion in the music (it's no longer clear).
- Turn the front level input control dial counter-clockwise until the music sounds clear again.
- Your front input level is now correctly set. Repeat this process with the rear and subwoofer channels.

9 Crossover-filter frequency controls (FREQ)

Turn the dial to the left to lower the crossover point, and to the right to raise it. Adjust the crossover until your subwoofer plays only low-frequency information.

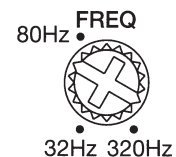

10 & 11 Power/Protect indicators

The power light will illuminate when the amplifier is getting power and playing. The protect indicator will illuminate in the event of conditions such as over/under voltage, short circuit, amplifier output circuit failure, or excessive heat.



12 Remote bass level control

To control the bass output remotely, plug the included controller into the Remote Level Control input. Mount the controller in a convenient location that doesn't interfere with normal vehicle operation.

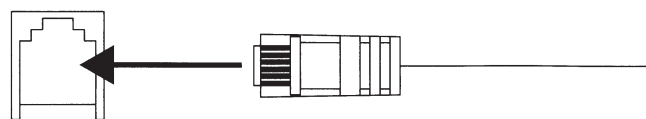

13 Bass boost: DBO (Dynamic Bass Optimizer)

You can increase the bass output up to +12 dB. Turn the dial to the right to increase the bass output.

BASS BOOST



0dB +12dB

14 Sub input selector

Select INT if you're connecting a subwoofer, but your source unit does not feature a subwoofer output (this sends a summed audio signal to the subwoofer). If your source unit does feature a subwoofer output, select EXT.

SUB INPUT

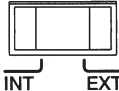

15 Subwoofer phase selector

You can choose a phase of 0° or 180°. Play music with lots of bass and slide the switch back and forth. Choose the setting that gives you more bass. If you don't detect any real difference, leave the dial at 0.

PHASE

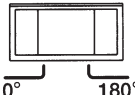

16 Subsonic high-pass filter (DBO: HP FREQ)

You can filter out inaudible low frequencies between 10 Hz and 80 Hz your sub might waste energy trying to reproduce. Turn the dial to the right to raise the frequency.



10Hz 80Hz
HP FREQ

SPECIFICATIONS

- Operating voltage: 9-16 volts
- RMS power @ 4 ohms: 75W x 4(Full), 200W x 1(Sub)
- RMS power @ 2 ohms: 100W x 4(Full), 350W x 1(Sub)
- RMS bridged power @ 4 ohms: 200W x 2 (Full)
- Total peak power: 2300W
- Quiescent current draw: $\leq 2A$
- High input maximum signal level: 20V
- High input maximum sensitivity: 2V
- Line input maximum signal level: 2V
- Line input maximum sensitivity: 0.2V
- Line-in signal-to-noise ratio (reference to 1 watt): $\geq 80dB$
- Fuse size: 3 x 30A
- THD + N at rated power: $\leq 0.1\%$
- Frequency response: 15Hz -35KHz@-3dB (Full)
10Hz - 320Hz (Sub)
- Crossover filter: LPF/HPF 32Hz – 320Hz Variable
12dB/Oct
- Bass EQ(Sub): 10Hz-80Hz variable 0-12dB
- Dimensions (H x W x D): 43.00mm x 177.00mm x
335.00mm
- Weight: 3.36kg

TROUBLESHOOTING

PROBLEM: No audio and POWER INDICATOR is off.

CAUSE and SOLUTION: No voltage at BATT+ and/or REM terminals, or bad or no ground connection. Check voltages at amplifier terminals with VOM.

PROBLEM: No audio and PROTECT INDICATOR flashes every 4 seconds.

CAUSE and SOLUTION: DC voltage on amplifier output. Amplifier may need service; see enclosed warranty card for service information.

PROBLEM: No audio and PROTECT and POWER INDICATORS flash.

CAUSE and SOLUTION: Voltage less than 9V on BATT+ connection. Check vehicle charging system.

PROBLEM: No audio and PROTECT INDICATOR is on.

CAUSE and SOLUTION: Amplifier is overheated. Make sure amplifier cooling is not blocked at mounting location. Verify that speaker-system impedance is within specified limits. Or, there may be voltage greater than 16V (or less than 8.5V) on BATT+ connection. Check vehicle charging system.

PROBLEM: Amplifier fuse keeps blowing.

CAUSE and SOLUTION: The wiring is connected incorrectly or there is a short circuit. Review installation precautions and procedures. Check wiring connections.

PROBLEM: Distorted audio.

CAUSE and SOLUTION: Gain is not set properly. Check INPUT LEVEL setting. Check speaker wires for shorts or grounds. Amplifier or source unit may be defective.

PROBLEM: Distorted audio and PROTECT INDICATOR flashes.

CAUSE and SOLUTION: Short circuit in speaker or wire. Remove speaker leads one at a time to locate shorted speaker or wire, and repair.

PROBLEM: Music lacks dynamics or "punch."

CAUSE and SOLUTION: Speakers are not connected properly. Check speaker connections for proper polarity.

PROBLEM: Engine noise—whining or clicking—in system when the engine is on.

CAUSE and SOLUTION: Amplifier is picking up alternator noise. Turn down gain. Move audio cables away from power wires. Install an alternator noise filter on power line between battery and alternator. Check ground connections on the amplifier – a loose or improper ground is one of the main causes for noise.



