



## INSTALLATION INSTRUCTIONS FOR PART 95-8246HG

# Toyota Tundra 2014-up 95-8246HG

### KIT FEATURES

- Double DIN radio provision
- *Painted high gloss black*



### KIT COMPONENTS

- A) Radio housing trim panel • B) Brackets • C) (4) #8 x 3/8" Phillips screws

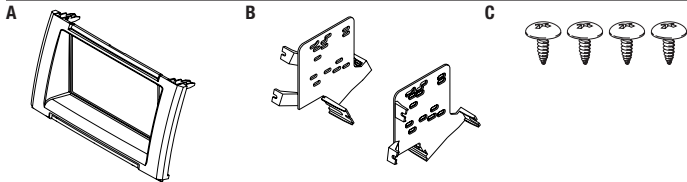

### WIRING & ANTENNA CONNECTIONS (sold separately)

Wiring Harness: • 70-1761 - Standard harness or TYTO-01 premium interface

Antenna Adapter: • 40-LX11

### TOOLS REQUIRED

- Panel removal tool • Phillips screwdriver • Socket wrench

### Table of Contents

Dash Disassembly .....	2
Kit Assembly .....	3

**CAUTION!** All accessories, switches, climate controls panels, and especially air bag indicator lights must be connected before cycling the ignition. Also, do not remove the factory radio with the key in the on position, or while the vehicle is running.

## Dash Disassembly

1. Unsnap and remove the factory climate controls. (Figure A)
2. Remove (4) 10 mm bolts securing the factory radio and remove it.

*Continue to kit assembly*

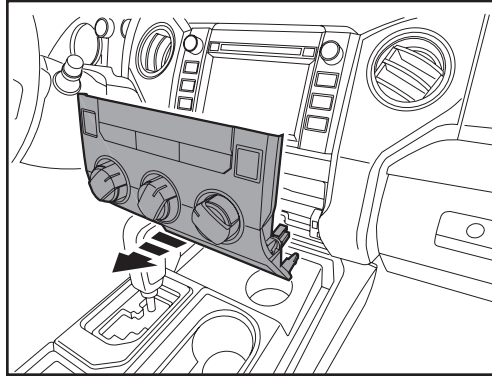

(Figure A)

## Kit Assembly

### Double DIN radio provision

1. Attach the factory panel clips to the *radio housing trim panel*.
2. Attach the *brackets* to the *radio housing trim panel* using (4) of the supplied #8 x 3/8" screws. (Figure A)
3. Slide the radio into the *bracket/radio housing* assembly and secure to the assembly using the screws supplied with the radio. (Figure B)
4. Locate the factory wiring harness in the dash. Metra recommends using the proper mating adapter from Metra or AXCESS. Re-connect the negative battery terminal and test the unit for proper operation.
5. Reassemble dash in reverse order of disassembly.

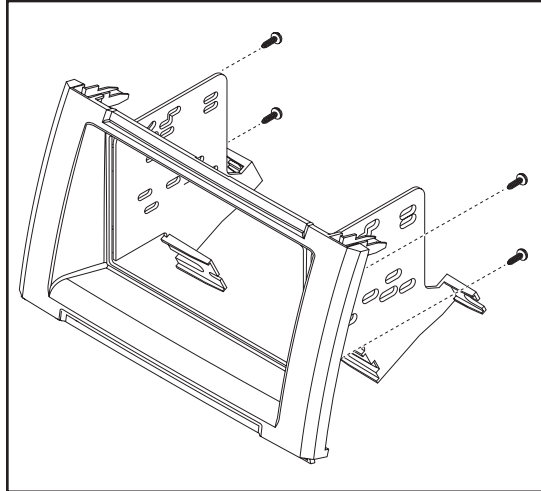

(Figure A)

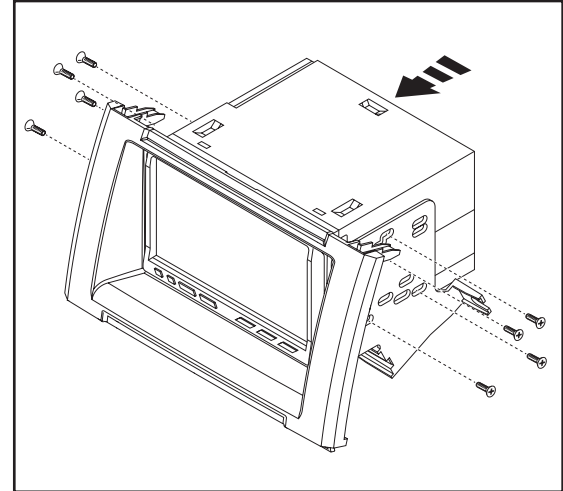

(Figure B)