



INSTALLATION INSTRUCTIONS FOR PART 95-7424

APPLICATIONS

Nissan Titan 2008-2012 95-7424



KIT FEATURES

- Double DIN radio provision
- *Painted silver to match factory dash*

KIT COMPONENTS

- A) Double DIN radio housing • B) Double DIN trim plate • C) Trim panel • D) Double DIN brackets
- E) (9) Panel clips • F) Two sided tape (not shown)

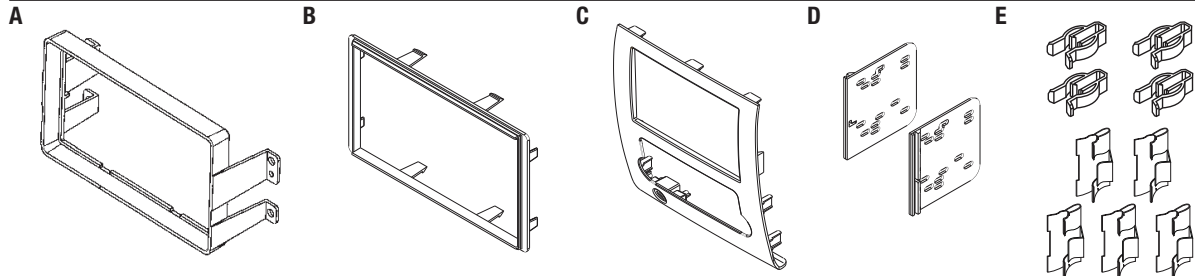

WIRING & ANTENNA CONNECTIONS (sold separately)

Wiring Harness: • 70-7550 - Nissan harness 1995-up

Antenna Adapter: • Not required

Table of Contents

Dash Disassembly

– Nissan Titan 2008-2012 2

Kit Preparation

– Nissan Titan 2008-2012 2-3

Kit Assembly

– Double DIN radio provision..... 3

TOOLS REQUIRED

- Panel removal tool • Phillips screwdriver
- Small flat blade screwdriver • Torx T-10 driver

CAUTION: Metra recommends disconnecting the negative battery terminal before beginning any installation. All accessories, switches, and especially air bag indicator lights must be plugged in before reconnecting the battery or cycling the ignition.

NOTE: Refer to the instructions included with the aftermarket radio.

REV. 5/14/2014 INST95-7424

Dash Disassembly

1. Unclip the entire dash panel including the radio and climate controls. Unplug and remove the panel. (Figure A)
2. Remove (4) Phillips screws securing the radio chassis. Unplug and remove the chassis. (Figure B)
3. Remove (4) T-10 Torx screws securing the climate controls to the dash panel and remove the controls from the panel (retain the screws and climate controls for re-use during kit preparation). (Figure C)
4. Remove (2) T10 Torx screws securing the passenger air bag status light assembly to the dash panel and remove the light from the panel (retain the screws and light for re-use during kit preparation). (Figure C)

Note: The small round Airbag sticker also needs to be removed from the factory panel and placed onto the 95-7424 radio housing panel (a round piece of double-sided tape is provided in case the factory sticker is not strong enough). (Figure C)

Continue to kit preparation

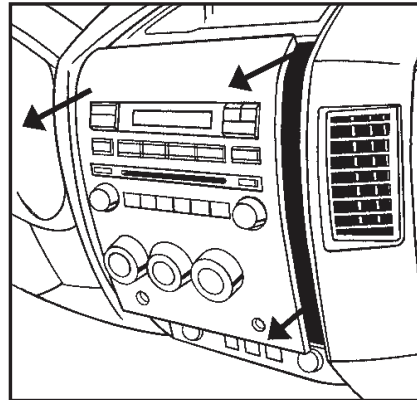

(Figure A)

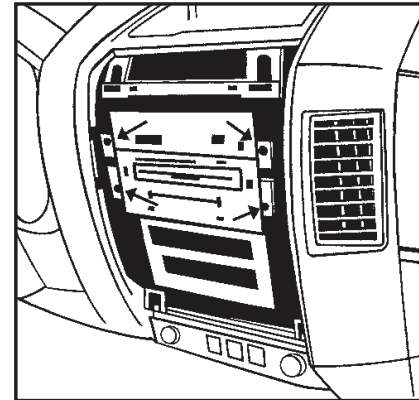

(Figure B)

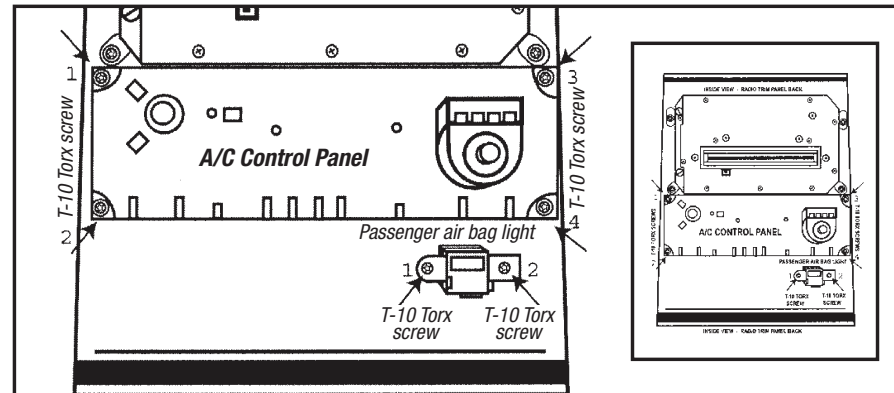

(Figure C)

Kit Preparation

1. Attach the climate controls to the Trim Panel using the factory hardware removed during the dash disassembly. (Figure A)
2. Attach the passenger air bag status light assembly to the Trim Panel using the factory hardware removed during the dash disassembly. (Figure B)

Also, apply to air bag button the small round airbag sticker previously removed in dash disassembly. (Figure B)

Continue to kit assembly

Kit Preparation

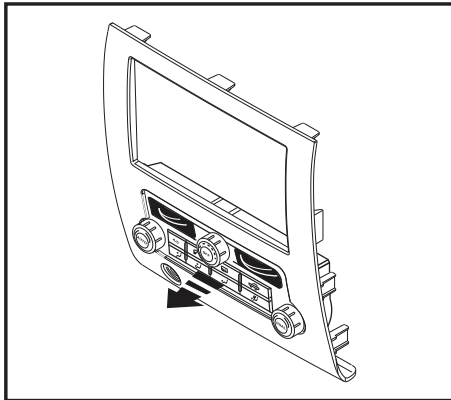

(Figure A)

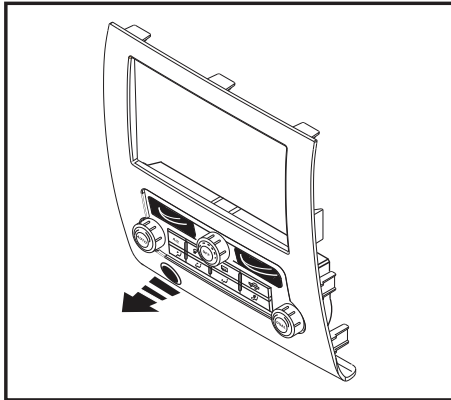

(Figure B)

Double DIN radio provision

1. Locate the factory wiring harness in the dash. Metra recommends using the proper mating adapter from Metra or AXXESS. Re-connect the negative battery terminal and test the unit for proper operation.
2. Snap the Double DIN brackets to the inside edge of the Double DIN radio housing. (Figure A)
3. Slide the Double DIN radio into the Double DIN bracket/radio housing assembly and secure the radio to the assembly using the screws supplied with the radio. (Figure B)
4. Snap the Double DIN trim-plate onto the housing/radio assembly. (Figure B)
5. Reassemble dash in reverse order of disassembly.

Kit Assembly

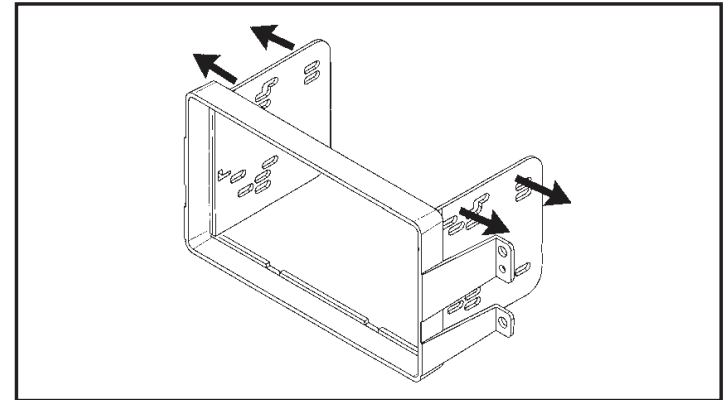

(Figure A)

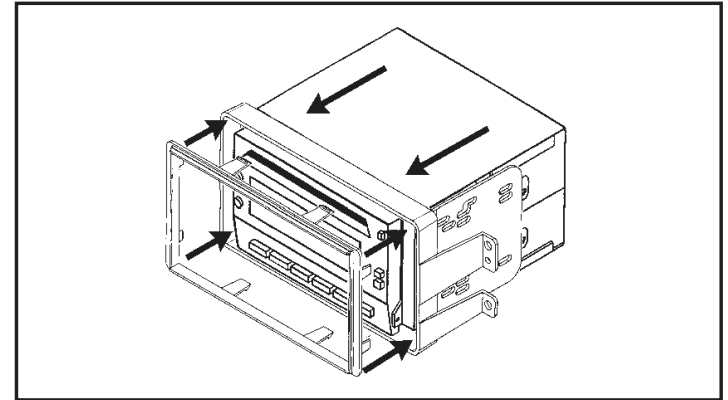

(Figure B)



INSTALLATION INSTRUCTIONS FOR PART 95-7424



REV. 5/14/2014 INST95-7424



KNOWLEDGE IS POWER

Enhance your installation and fabrication skills by enrolling in the most recognized and respected mobile electronics school in our industry. Log onto www.installerinstitute.com or call 800-354-6782 for more information and take steps toward a better tomorrow.



Metra recommends MECP certified technicians