



### Installation instructions for part 99-76295

## Nissan Armada/Titan w/ Factory NAV 2004-2007 99-76295



### KIT FEATURES

- ISO DIN radio provision with pocket
- ISO DDIN radio provision
- *Painted to match factory dash panel*

### KIT COMPONENTS

- A) Radio trim panel • B) Radio brackets • C) Pocket • D) (10) #8 x 3/8" Phillips screws • E) (6) Panel clips
- F) Rear A/C delete plugs

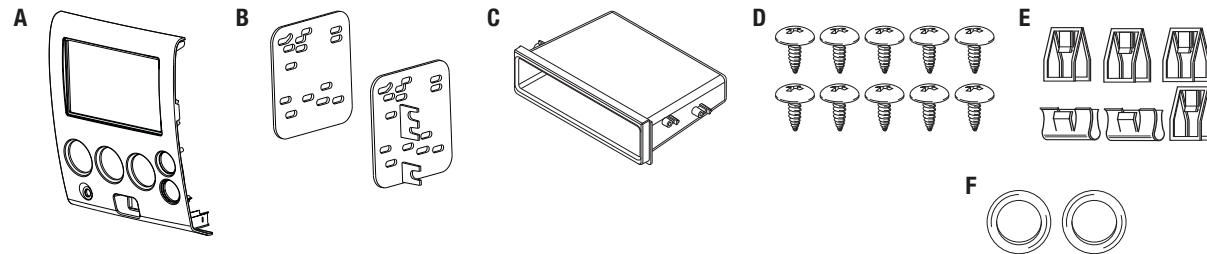

### WIRING & ANTENNA CONNECTIONS (sold separately)

Wiring Harness: • 70-7550

Antenna Adapter: • Not required

### Table of Contents

Dash Disassembly .....	2
Kit Preparation .....	3
<b>Kit Assembly</b>	
– ISO DIN radio provision with pocket.....	3
– ISO DDIN radio provision .....	4

### TOOLS REQUIRED

- Panel removal tool • Phillips screwdriver
- Torx T-10 driver

**CAUTION!** Metra recommends disconnecting the negative battery terminal before beginning any installation, unless the vehicle manufacturer recommends against so. Please check with your local Dealership for more information. All accessories, switches, climate controls panels, and especially air bag indicator lights must be connected before reconnecting the battery or cycling the ignition. Also, do not remove the factory radio with the key in the on position, or the vehicle running. It would be best to remove the key from the ignition and then wait a few seconds before removing the factory radio.

REV. 11/15/2015 INST99-76295

## Dash Disassembly

### Vehicle:

1. Unclip and remove the climate-control/radio panel. (Figure A)
2. Remove (4) screws securing the radio to the sub-dash and then remove. (Figure B)

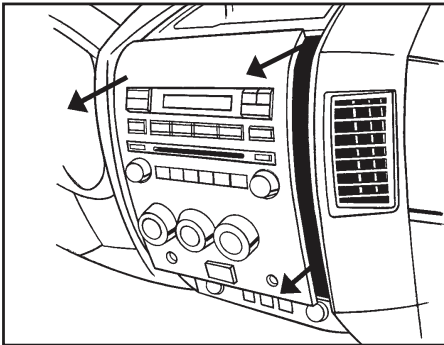

(Figure A)

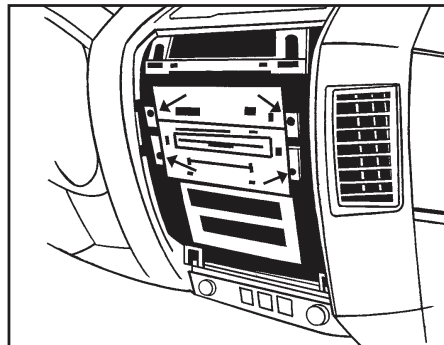

(Figure B)

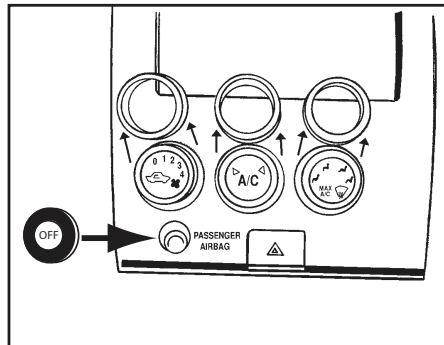

(Figure C)

### Climate-control/radio panel:

3. Unsnap and remove the (3) outer trim rings from the climate control knobs. (Figure C)
4. Remove (4) T-10 Torx screws to separate the factory radio trim panel. (Figure D)
5. Unclip and remove the hazard light switch assembly.
6. Remove (2) T-10 Torx screws securing the passenger air bag light assembly and then remove. (Figure D)

**Note:** The small round sticker also needs to be removed from the factory panel and placed onto the 99-76295 radio trim panel.

Continue to kit preparation

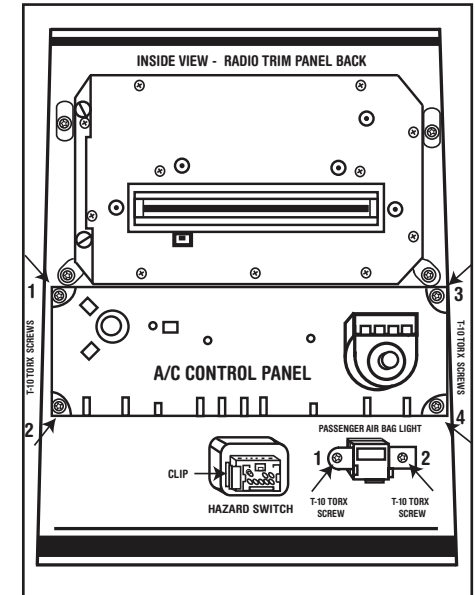

(Figure D)

## Kit Preparation

### To the 99-7629S radio trim panel:

1. Attach the factory climate controls using (4) #8 X 3/8" Phillips screws supplied. (Figure A)
2. Snap the outer trim rings onto the climate control knobs. (Figure B)
3. Attach the passenger air bag light assembly using (2) #8 X 3/8" Phillips screws supplied. (Figure C)

**Note:** Apply the small round airbag sticker previously removed to the air bag button.

4. Snap in the hazard light switch. (Figure D)
5. Attach (6) panel clips using the factory radio panel as a reference for clip positioning.
6. For models without rear A/C, snap in the (2) rear A/C delete plugs.

Continued to kit assembly

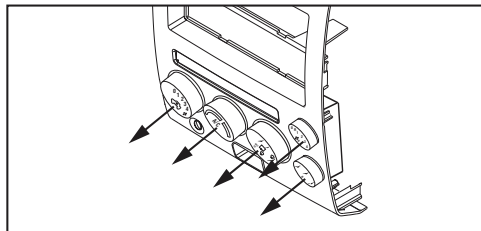

(Figure A)

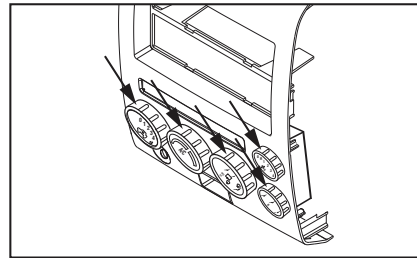

(Figure B)

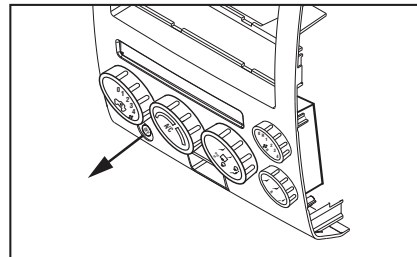

(Figure C)

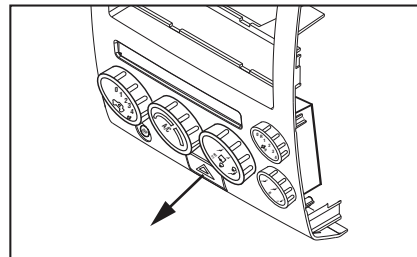

(Figure D)

## Kit Assembly

### ISO DIN radio provision with pocket

1. Secure the *radio brackets* to the *pocket* using (4) #8 x 3/8" Phillips screws supplied. (Figure A)
2. Remove the metal DIN sleeve and trim ring from the aftermarket radio.
3. Slide the radio in the pocket/ bracket assembly, and then secure to the assembly using the screws provided with the radio. (Figure B)
4. Locate the factory wiring harness and antenna connector in the dash, and complete all necessary connections to the radio. Metra recommends using the proper mating adapter from Metra and/or AXXESS. Re-connect the negative battery terminal and test the radio for proper operation.
5. Reassemble the dash in reverse order of disassembly, using the 99-7629S *radio trim panel*.

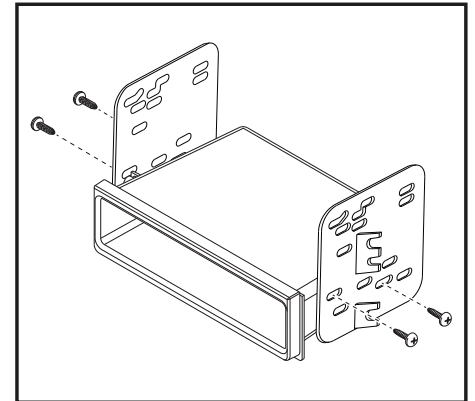

(Figure A)

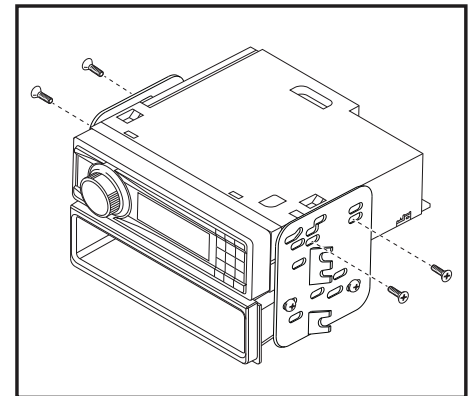

(Figure B)



## Installation instructions for part 99-7629S



### Kit Assembly

#### ISO DDIN radio provision

1. Secure the *radio brackets* to the radio using screws provided with the radio. (Figure A)
2. Locate the factory wiring harness and antenna connector in the dash, and complete all necessary connections to the radio. Metra recommends using the proper mating adapter from Metra and/or AXXESS. Re-connect the negative battery terminal and test the radio for proper operation.
3. Reassemble the dash in reverse order of disassembly, using the 99-7629S *radio trim panel*.

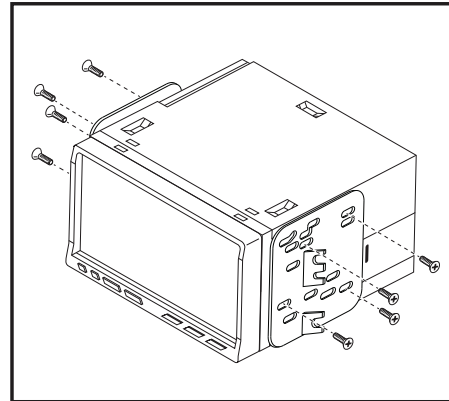

(Figure A)

### IMPORTANT

If you are having difficulties with the installation of this product, please call our Tech Support line at **1-800-253-TECH**. Before doing so, look over the instructions a second time, and make sure the installation was performed exactly as the instructions are stated. Please have the vehicle apart and ready to perform troubleshooting steps before calling.



#### KNOWLEDGE IS POWER

Enhance your installation and fabrication skills by enrolling in the most recognized and respected mobile electronics school in our industry. Log onto [www.installerinstitute.com](http://www.installerinstitute.com) or call 800-354-6782 for more information and take steps toward a better tomorrow.



**Metra recommends MECP certified technicians**