



**! IMPORTANT**

If you choose to perform the installation yourself, it is absolutely vital that the Stealthbox® be properly mounted to the vehicle according to these instructions. Failure to mount the enclosure properly presents two problems:

- 1) The sub-bass performance will suffer due to the movement of the enclosure caused by the force exerted by the woofer(s).
- 2) A loose enclosure presents a serious safety hazard in the event of a collision or sudden deceleration.

INSTALLATION  
DIFFICULTY:

**2** OUT OF **5**

ESTIMATED TIME:  
2 HOURS



**Stealthbox®**  
INSTALLATION GUIDE  
for the

**SB-CAN-MVX3/10TW3**  
SKU# 94646

**2017 & Up Can-Am Maverick X3 2-seat (Driver)**

**Enclosure Type:** Sealed

**Driver Type:** 10TW3-D4

**Nominal Impedance:** 2 ohms

**Continuous Power Handling:** 400 watts (RMS method)

*Thank you for choosing a JL Audio Stealthbox® for your automotive sound system. With proper installation, your new vehicle-specific enclosed subwoofer system will deliver years of listening pleasure.*

*We strongly recommend that you have your new Stealthbox® installed by your authorized JL Audio dealer. The installation professionals employed by your dealer have the necessary tools and experience to disassemble and reassemble your vehicle properly. If you prefer to perform your own installation, please read this installation guide completely before beginning the process.*

**INCLUDED HARDWARE**

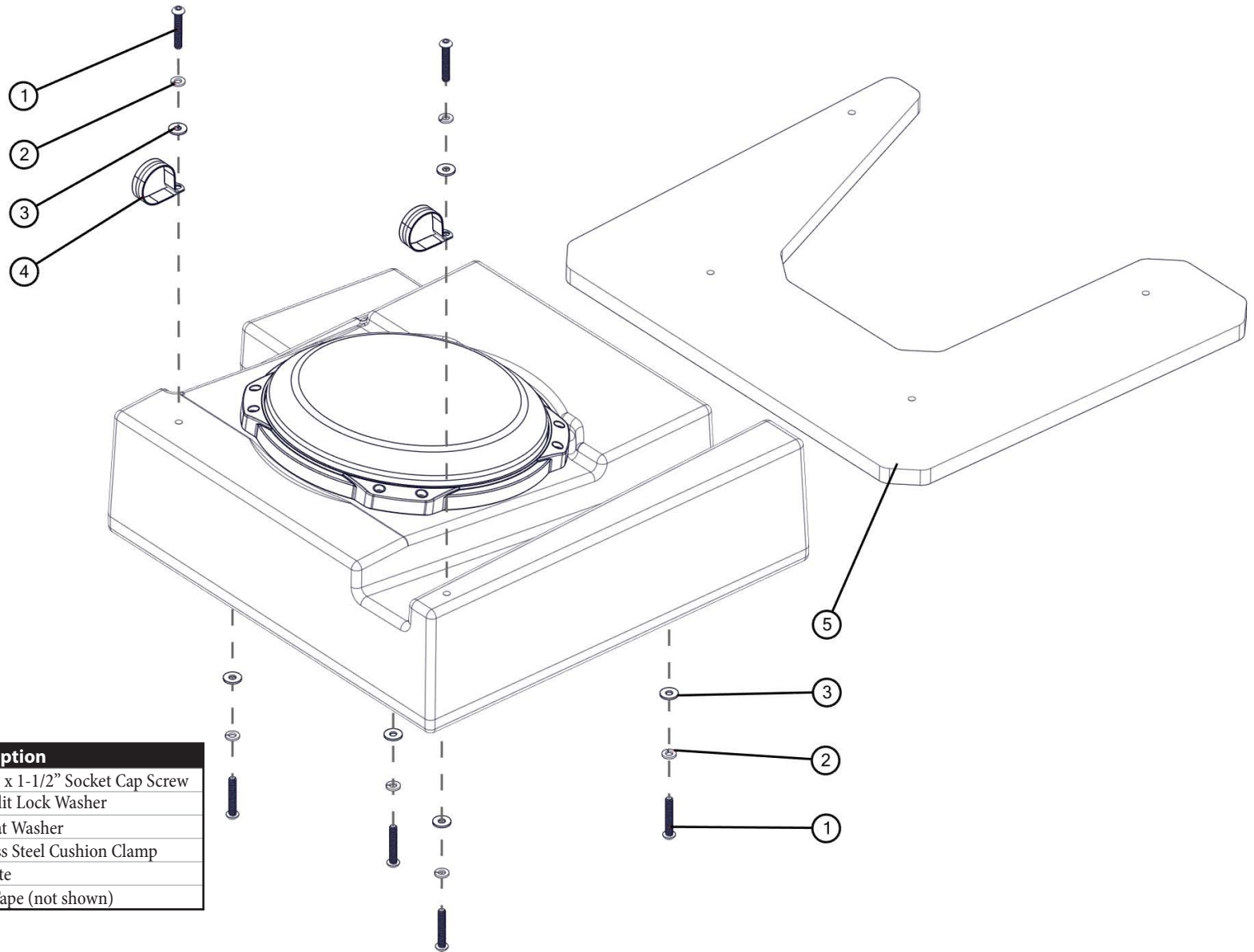

BOM ID	Qty	SKU	Description
1	6	151709	1/4 - 20 x 1-1/2" Socket Cap Screw
2	6	150066	1/4" Split Lock Washer
3	6	153734	1/4" Flat Washer
4	2	153764	Stainless Steel Cushion Clamp
5	1	152431	Template
-	1	150249	Foam Tape (not shown)

**Note: For optimum performance, JL Audio recommends applying the included Foam Strips (or sound damping material) to surrounding plastic panels to reduce unwanted vibrations.**

## POWER RECOMMENDATION

JL Audio recommends high quality amplifiers such as the JL Audio MX300/1. The diagram below shows the recommended crossover settings for the MX300/1. For a detailed description of the amplifier settings, consult the owner's manual for the amplifier. If another amplifier is being used, please reference this illustration and use similar settings on that amplifier.

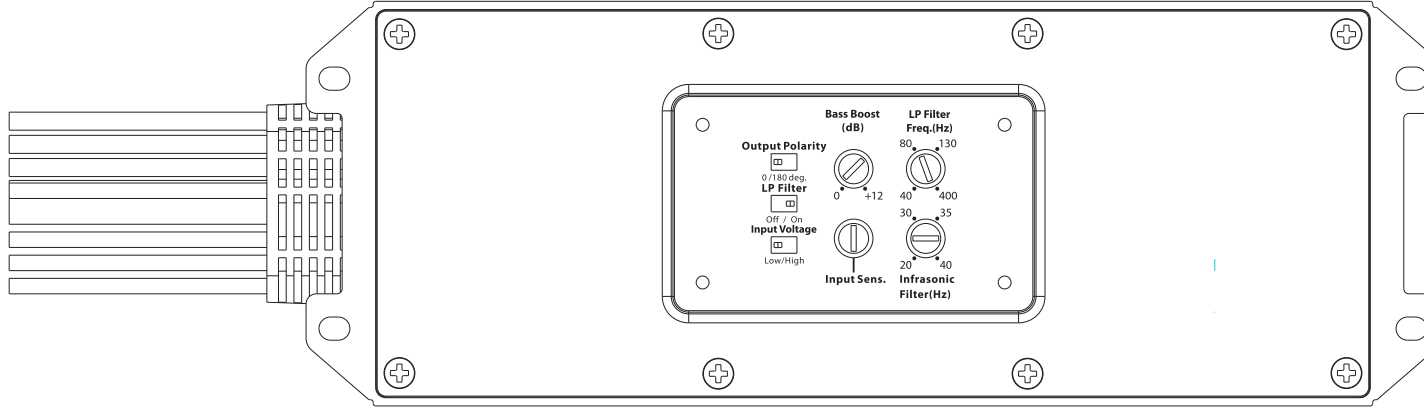

## CONNECTIONS

Using quality power, signal, and speaker wire is essential in ensuring the performance of your Stealthbox®. JL Audio recommends using a 4 AWG power kit such as the XD-PCS4-1B for your Stealthbox® amplifier. Other kits are available should you be using more than one amplifier. Signal wire such as the JL Audio Premium Audio Interconnect Cables should be used to provide signal for both channels of the amplifier. JL Audio recommends using 12AWG speaker wire for subwoofers such as our XC-BCS12-25.



**STEP 1**

Empty the front of the vehicle.



**STEP 2**

Remove the two front seat bolts from the driver's seat bracket.



**STEP 3**

Slide the driver's seat forward.

Remove the two rear seat bolts from the seat bracket.



**STEP 4**

Remove the seat belt bolt.



**STEP 5**

Unplug the seat belt wiring harness.

Carefully remove the driver's seat from the vehicle.

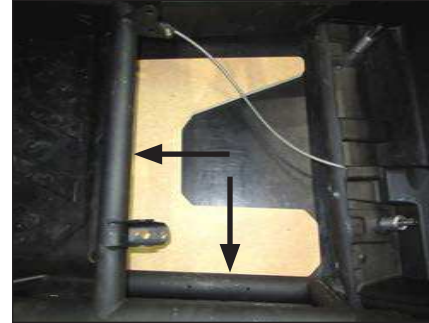

**STEP 6**

Position the Template on the vehicle floor. Push the Template forward and to the outside, as shown, until flush with the frame rails.



**STEP 7**

Using a small pick tool, mark each of the hole locations through the Template onto the plastic floor panel.



**STEP 8**

Remove the Template from the vehicle.

Using a 1/8" drill bit, drill a pilot hole through each of the marks made in the previous step.



**STEP 9**

Using a 5/16" drill bit, enlarge each of the pilot holes drilled in the previous step.



**STEP 10**

Place the Stealthbox® face down on a flat surface. Attach Foam Tape to the bottom of the enclosure, as shown.



**STEP 11**

Completely loosen the eight subwoofer mounting screws, but do not remove them.



**STEP 12**

Carefully set the enclosure into the vehicle, as shown.



**STEP 13**

Partially lift the subwoofer out of the enclosure, as shown. This allows for clearance to position the enclosure in the next step.



**STEP 14**

Push the enclosure forward, allowing it to drop into position. Place the subwoofer back into the enclosure.



**STEP 15**

Tighten the eight subwoofer mounting screws.



**STEP 16**

Slide a 1/4" Split Lock Washer and a 1/4" Flat Washer over each of four 1/4 - 20 x 1-1/2" Socket Cap Screws.

From under the vehicle, pass each assembly through a drilled hole in the floor panel, into a threaded insert in the bottom of the enclosure, and fully tighten.

**STEP 18**

Wrap a Stainless Steel Cushion Clamp over the inside front frame rail, aligning its holes with the threaded insert in the top of the enclosure.

Slide a 1/4" Split Lock Washer and a 1/4" Flat Washer over a 1/4 - 20 x 1-1/2" Socket Cap Screw, pass the assembly through the holes in the Stainless Steel Cushion Clamp, and into the threaded insert.

**STEP 19**

Repeat the process for the outside front frame rail position.

Fully tighten both 1/4 - 20 x 1-1/2" Socket Cap Screws.

**STEP 20**

Pictured is the Stealthbox® completely secured.

Connect speaker cable to the barrier strip on the back of the enclosure, and route the cable as necessary.

**STEP 21**

Carefully reinstall the driver's seat.

Connect the seat belt harness, reinstall the seat belt bolt, the two rear seat bolts, and the two front seat bolts.

Note: For optimum performance, we recommend applying the included Foam Strips (or sound damping material) to surrounding plastic panels to reduce unwanted vibrations.

**CONGRATULATIONS!**

You have completed the installation for this model! Enjoy your new Stealthbox®!

**MID/HIGH FREQUENCY DRIVER FITMENT**

VeX™ Enclosed Speaker Systems are ideal for powersports and off-road vehicle applications. Each weatherproof pod can be mounted to a roll cage precisely aimed for optimum sound. Mounting fixtures are available to fit a variety of roll cage diameters.



**JL AUDIO** | How we play.®    

(954) 443-1100

[www.jlaudio.com](http://www.jlaudio.com)

All specifications are subject to change without notice. "JL Audio" and "How we play" are registered trademarks of JL Audio, Inc. "Ahead of the Curve" and its respective logo are trademarks of JL Audio, Inc.  
Printed in USA • ©2017 JL Audio, Inc. • For more detailed information please visit us online at [www.jlaudio.com](http://www.jlaudio.com).

JLA-SKU# 011492 • ver. 11.06.2018 • 10369 NORTH COMMERCE PARKWAY • MIRAMAR, FLORIDA • 33025 • USA



\*011492\*