

Product Features

- Retains factory features in select GM Class II Data Bus vehicles while functioning with an aftermarket radio.
- Retains chime functions such as: seat belt, check engine, key in ignition, low fuel, low oil and lights on.
- Retains RAP (Retained Accessory Power).

Vehicle Applications

Buick

2004-2005	Century
2005-2007	LaCrosse
2004-2007	Rainier
2003-2005	Rendezvous
2005-2007	Terraza

Cadillac

2003-2006	Escalade
-----------	----------

Chevrolet

2003-2006	Avalanche
2000-2005	Cavalier
2004-2013	Colorado
2005-2013	Corvette
2004-2007	Express
2000-2005	Impala
2000-2005	Monte Carlo
2003-2004	S-10
2003-2006	Silverado
2007	Silverado Classic
2003-2006	SSR
2003-2006	Suburban
2003-2006	Tahoe
2002-2009	Trailblazer
2005-2008	Uplander
2003-2005	Venture

GMC

2004--2011	Canyon
2002-2009	Envoy
2003-2007	Savana
2003-2006	Sierra
2007	Sierra Classic
2003-2006	Yukon

Hummer

2003-2007	H2
2005-2009	H3

Isuzu

2003-2008	Ascender
-----------	----------

Oldsmobile

2001-2004	Alero
2002-2004	Bravada
2000-2004	Silhouette

Pontiac

2001-2005	Aztek
2001-2005	Grand Am
2004-2008	Grand Prix
2000-2006	Montana
2000-2005	Sunfire

Saab

2005-2008	9-7X
-----------	------

Saturn

2005-2007	Relay
-----------	-------

Parts Included



GM-17 Module



GM-17 Harness





Installation Diagram

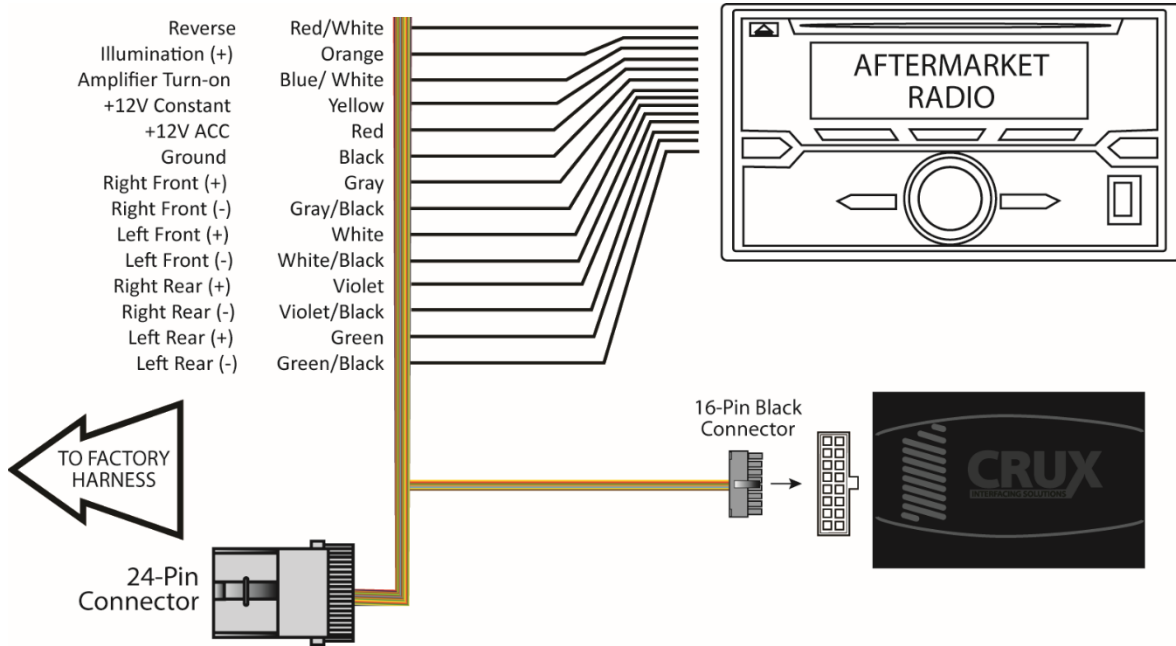

NOTES:

- Not compatible with BOSE system. Use part# SOCGM-17C for vehicles with BOSE audio system.
- Does not retain OnStar
- Does not retain Steering Wheel Controls.
- A relay may be needed for radios that require more than 3 amps power. See connection diagram below.
An instance when a relay is needed is when the radio power cuts on and off.

