



# JBL STADIUM 122SSI 12 Inch (300mm) High-Performance Car Audio Subwoofer Owner's Manual

[Home](#) » [JBL](#) » JBL STADIUM 122SSI 12 Inch (300mm) High-Performance Car Audio Subwoofer Owner's Manual



by **HARMAN**

**STADIUM 122SSI 12 Inch (300mm) High-Performance Car Audio Subwoofer  
Owner's Manual**

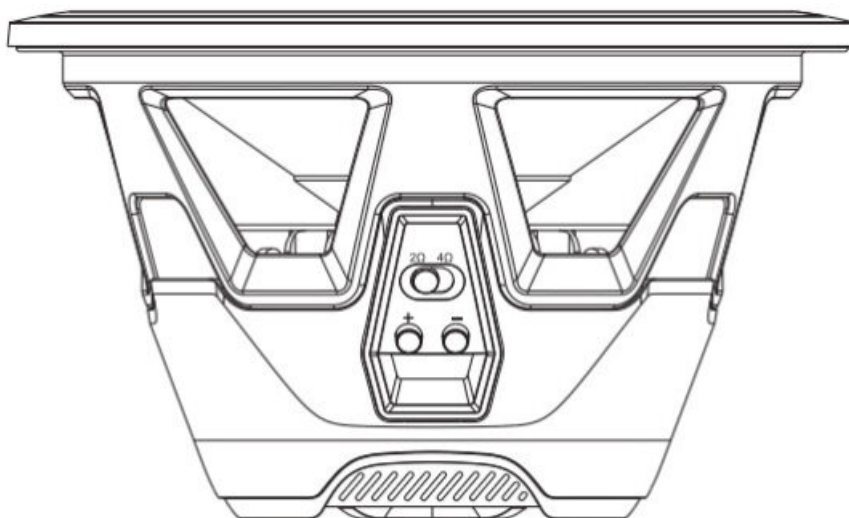

**STADIUM 122SSI**

## THANK YOU

for choosing an Infinity Kappa subwoofer. These subwoofers are designed to suit a broad range of car audio applications and can be used in a wide variety of enclosure types to produce extended, powerful bass in a limited amount of vehicle space. To get the most performance from your new subwoofer, it is strongly recommended that you have a qualified professional to install your subwoofer. Although this manual does provide general instructions about

installing these Kappa subwoofers, it does not include enclosure construction details or exact installation methods for any particular vehicle. If you do not feel that you have the necessary experience, do not attempt the installation yourself, but instead ask your authorized Infinity dealer about professional installation options.

Remember to keep your sales receipt in a safe place, along with this manual, so that both are available for future reference.

## Contents

[1 WARNING](#)

[2 REPRODUCING BASS IN VEHICLES](#)

[3 SUBWOOFER ENCLOSURE TYPES](#)

[4 MOUNTING THE SUBWOOFER](#)

[5 CONNECTING THE SUBWOOFER](#)

[6 CONNECTING THE AMPLIFIER](#)

[7 TECHNICAL DATA](#)

[8 SPECIFICATIONS](#)

[9 Documents / Resources](#)

[9.1 References](#)

[10 Related Posts](#)

## WARNING

Playing loud music in a vehicle can hinder your ability to hear traffic and permanently damage your hearing. The maximum volume levels achievable by Infinity speakers when combined with high-power amplification may exceed safe levels for extended listening. Using low volume levels is recommended when driving. Infinity, Inc. accepts no liability for hearing loss, bodily injury, or property damage as a result of the use or misuse of this product.

## REPRODUCING BASS IN VEHICLES

Depending on the size of your vehicle's interior listening space, reproduced bass frequencies below 80Hz will be boosted by nearly 12dB per octave as frequency decreases. This phenomenon, known as the vehicle's transfer function (or cabin gain), plays an important role in shaping the subwoofer's frequency response in your vehicle.

## SUBWOOFER ENCLOSURE TYPES

The subwoofers are designed to perform best in moderately sized sealed enclosures, vented enclosures, and prefabricated band-pass enclosures. Infinite-baffle mounting is possible, but the subwoofer's mechanical power handling will be reduced because there will be no volume of air to stiffen the subwoofer's suspension and prevent over-excursion. If you choose infinite-baffle mounting, consider the RMS and peak power-handling ratings to be half of what is listed in the specifications in this manual.

You should choose an enclosure type based on the amount of cargo space you can devote to the enclosure, the amount of power you will use to drive your subwoofer(s), and your listening habits.

## SEALED ENCLOSURES

The air trapped inside a sealed enclosure is compressed when the subwoofer moves rearward and is rarefied when the subwoofer moves forward. In both cases, the air inside and outside the box will seek equilibrium by pushing and pulling on the subwoofer cone. The result is a stiffer suspension when compared to the subwoofer operating in free air. This means that the subwoofer's cone will be harder to move at low frequencies, a condition that protects the subwoofer from physical over-excursion but requires more power than other designs to achieve a

given acoustic output.

## **SEALED-ENCLOSURE PERFORMANCE ADVANTAGES**

- The in-vehicle performance will have the flattest overall frequency response.
- The in-vehicle response will have the widest bandwidth. (Usable low-frequency response inside the vehicle will be below 20Hz.)
- An optimum sealed enclosure will always be smaller than an optimum enclosure of another type.

## **SEALED-ENCLOSURE PERFORMANCE TRADE-OFFS**

- An optimum sealed enclosure will have lower overall efficiency than an optimum enclosure of another type.
- A subwoofer in an optimum sealed enclosure will require more amplifier power to achieve a given acoustic output than in an optimum enclosure of another type.

## **SEALED-ENCLOSURE CONSTRUCTION**

Sealed-enclosure construction is straightforward and forgiving of errors in volume calculation, but air leaks should be avoided. Use medium-density fiberboard (MDF), glue, and screws to construct the enclosure, and seal all joints with silicone caulk.

## **RECOMMENDATION**

Subwoofers in sealed enclosures are recommended for enthusiasts who prefer accurate music reproduction and flat frequency response, for those who have a smaller space to devote to a subwoofer enclosure, and for those who have plenty of amplifier power devoted to driving the subwoofer. The sealed-enclosure design indicated in this manual represents the best compromise between low-frequency extension and flat response.

## **VENTED ENCLOSURES**

A vented enclosure acts as a sealed enclosure at frequencies above its tuned (resonance) frequency. At resonance (which is defined by the vent), the vent produces the majority of sound – the subwoofer cone is nearly stationary while the air inside the vent vibrates. This provides greater mechanical power handling at and above resonance but reduced mechanical power handling below resonance. Since the subwoofer cone and voice coil don't move much at resonance, airflow across the voice coil is minimized and thermal power handling is reduced slightly at resonance.

Vented enclosures provide better efficiency in the 40Hz – 60Hz range, at the expense of sound output in the lowest octave (below 40Hz). The use of an infrasonic filter is recommended with vented enclosures. An optimum vented enclosure for a Kappa subwoofer is larger than an optimum sealed enclosure.

## **VENTED-ENCLOSURE PERFORMANCE ADVANTAGES**

- An optimum vented enclosure has greater efficiency and higher output in the 40Hz – 60Hz range than an optimum sealed enclosure.
- An optimum vented enclosure provides a greater sensation of bass than an optimum sealed enclosure.
- A subwoofer in an optimum vented enclosure will require less amplifier power to achieve a given acoustic output (down to the enclosure's resonance frequency) than in an optimum sealed enclosure.

## **VENTED-ENCLOSURE PERFORMANCE TRADE-OFFS**

- Reduced output in the lowest octave (below 40Hz).
- Reduced mechanical power handling below the enclosure's resonance frequency. The use of an electronic infrasonic filter is strongly recommended to reduce the chance of overdriving the subwoofer below the enclosure's resonance frequency.
- An optimum vented enclosure will always be larger than an optimum sealed enclosure.

## **VENTED-ENCLOSURE CONSTRUCTION**

Vented-enclosure construction is more difficult than the construction of a sealed enclosure. The enclosure volume and port dimensions have a specific relationship with the physical and electromechanical characteristics of the subwoofer, requiring that the recommended enclosure volume and port characteristics be strictly observed. As with sealed enclosures, use medium-density fiberboard (MDF), glue, and screws to construct the enclosure, and seal all joints with silicone caulk.

## **RECOMMENDATION**

Subwoofers in vented enclosures are recommended for enthusiasts who prefer accentuated bass response, for those who have plenty of cargo space to devote to a subwoofer enclosure, and for those who will use a less powerful amplifier to drive their subwoofer. The volume and port dimensions indicated must be followed precisely to ensure optimum performance.

## **MOUNTING THE SUBWOOFER**

The subwoofers should be mounted from the outside of the enclosure. Use the included foam mounting gasket to ensure a leak-free seal between the subwoofer frame and the enclosure.

## **CONNECTING THE SUBWOOFER**

### **SETTING THE IMPEDANCE**

The Kappa subwoofers both feature the Selectable Smart Impedance™ (SSI) switch. This exclusive feature lets you set the subwoofer's impedance to either 2 ohms or 4 ohms with the flip of a switch (see illustrations below). This allows you to extract the most from your subwoofer amplifier in any situation.

The SSI 2-ohm setting increases the subwoofer's output over the 4-ohm setting by up to 3dB, depending on the amplifier. Performance is identical in all other respects. If the connected amplifier is rated for 2-ohm operation and its 2-ohm power ratings are within the subwoofer's power-handling specifications, setting the SSI switch in the 2-ohm position will achieve maximum output.

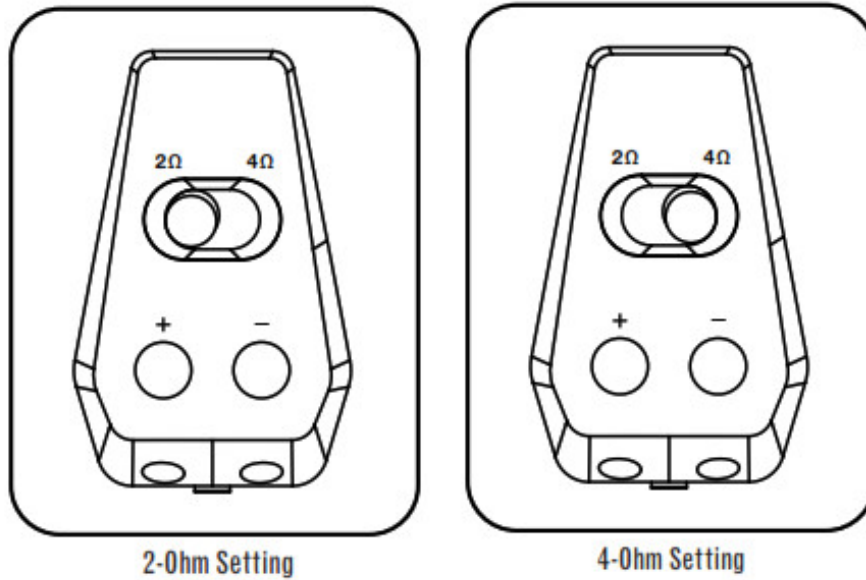

**IMPORTANT:** Make sure the subwoofer amplifier is turned OFF before setting the SSI switch. Do not change the switch position while the subwoofer amplifier is operating. Doing so could damage the amplifier.

## CONNECTING THE AMPLIFIER

The subwoofer connectors are compatible with bare or tinned wires. The recommended wire gauge is between 14AWG and 8AWG, depending on the length of the wire run between the amplifier and woofer. Heavier gauge wire is preferred for runs over 6' (2m).

1. Use a 2.5 mm hex driver to open the connectors
2. Insert the wire ends into the connector openings

**NOTE:** If using untinned bare wire, be sure that no stray “+” and “-” strands touch each other. Touching strands can cause a short-circuit, which can damage your amplifier.

3. Use the hex driver to secure the wires in the connectors, as shown in the illustration to the left

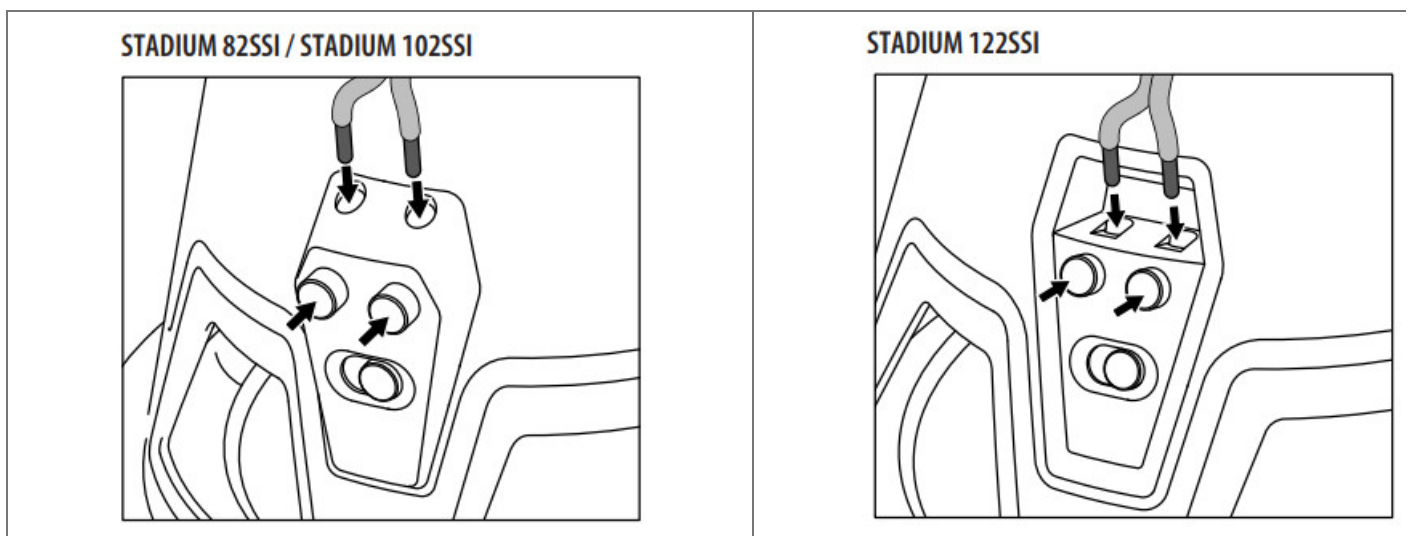

## TECHNICAL DATA

### THIELE-SMALLPARAMETERS

THIELE-SMALL PARAMETERS			2Ω	4Ω	THIELE-SMALL PARAMETERS			2Ω	4Ω	THIELE-SMALL PARAMETERS			2Ω	4Ω
VOICE-COIL DC RESISTANCE:	REVC (OHMS)	.....	2.26	4.71	VOICE-COIL DC RESISTANCE:	REVC (OHMS)	.....	2.58	4.92	VOICE-COIL DC RESISTANCE:	REVC (OHMS)	.....	2.55	4.78
VOICE-COIL INDUCTANCE @ 1kHz:	LEVC (mH)	.....	1.48	1.406	VOICE-COIL INDUCTANCE @ 1kHz:	LEVC (mH)	.....	1.444	1.28	VOICE-COIL INDUCTANCE @ 1kHz:	LEVC (mH)	.....	1.382	1.267
DRIVER RADIATING AREA:	SD (in <sup>2</sup> )	.....	35.18	35.18	DRIVER RADIATING AREA:	SD (in <sup>2</sup> )	.....	51.15	51.15	DRIVER RADIATING AREA:	SD (in <sup>2</sup> )	.....	85.5	85.5
	SD (cm <sup>2</sup> )	.....	226.98	226.98		SD (cm <sup>2</sup> )	.....	330.06	330.06		SD (cm <sup>2</sup> )	.....	551.55	551.55
MOTOR FORCE FACTOR:	BL (T <sub>a</sub> )	.....	10.375	13.87	MOTOR FORCE FACTOR:	BL (T <sub>a</sub> )	.....	11.785	15.776	MOTOR FORCE FACTOR:	BL (T <sub>a</sub> )	.....	11.39	15.49
COMPLIANCE VOLUME:	VAS (FT <sup>3</sup> )	.....	0.32	0.344	COMPLIANCE VOLUME:	VAS (FT <sup>3</sup> )	.....	0.452	0.462	COMPLIANCE VOLUME:	VAS (FT <sup>3</sup> )	.....	1.43	1.51
	VAS (LITERS)	.....	9.12	9.759		VAS (LITERS)	.....	12.81	13.1		VAS (LITERS)	.....	40.48	42.83
SUSPENSION COMPLIANCE:	CMS (μM/N)	.....	125	134	SUSPENSION COMPLIANCE:	CMS (μM/N)	.....	83	85	SUSPENSION COMPLIANCE:	CMS (μM/N)	.....	94	99
MOVING MASS, AIR LOAD:	MMS (GRAMS)	.....	113.48	105.9	MOVING MASS, AIR LOAD:	MMS (GRAMS)	.....	157.21	156.2	MOVING MASS, AIR LOAD:	MMS (GRAMS)	.....	220.55	209.44
FREE-AIR RESONANCE:	FS (Hz)	.....	42.2	42.3	FREE-AIR RESONANCE:	FS (Hz)	.....	43.1	42.8	FREE-AIR RESONANCE:	FS (Hz)	.....	33.8	33.7
MECHANICAL Q:	QMS	.....	4.13	2.438	MECHANICAL Q:	QMS	.....	4.516	2.888	MECHANICAL Q:	QMS	.....	6.225	3.581
ELECTRICAL Q:	QES	.....	0.632	0.689	ELECTRICAL Q:	QES	.....	0.825	0.866	ELECTRICAL Q:	QES	.....	0.983	0.945
TOTAL Q:	QTS	.....	0.548	0.537	TOTAL Q:	QTS	.....	0.697	0.666	TOTAL Q:	QTS	.....	0.849	0.748
MAGNETIC-GAP HEIGHT:	HAG (IN)	.....	3.15	3.15	MAGNETIC-GAP HEIGHT:	HAG (IN)	.....	3.15	3.15	MAGNETIC-GAP HEIGHT:	HAG (IN)	.....	3.15	3.15
	HAG (MM)	.....	8	8		HAG (MM)	.....	8	8		HAG (MM)	.....	8	8
VOICE-COIL HEIGHT:	HVC (IN)	.....	11.2	11.2	VOICE-COIL HEIGHT:	HVC (IN)	.....	11.2	11.2	VOICE-COIL HEIGHT:	HVC (IN)	.....	11.2	11.2
	HVC (MM)	.....	28.5	28.5		HVC (MM)	.....	28.5	28.5		HVC (MM)	.....	28.5	28.5
MAXIMUM EXCURSION:	XMAX (IN)	.....	4.03	4.03	MAXIMUM EXCURSION:	XMAX (IN)	.....	4.03	4.03	MAXIMUM EXCURSION:	XMAX (IN)	.....	4.03	4.03
	XMAX (MM)	.....	10.25	10.25		XMAX (MM)	.....	10.25	10.25		XMAX (MM)	.....	10.25	10.25

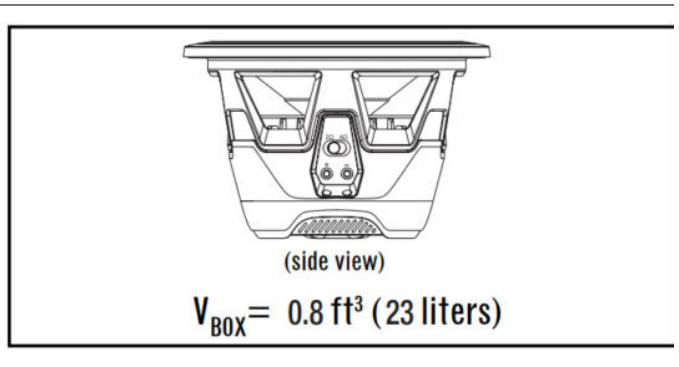
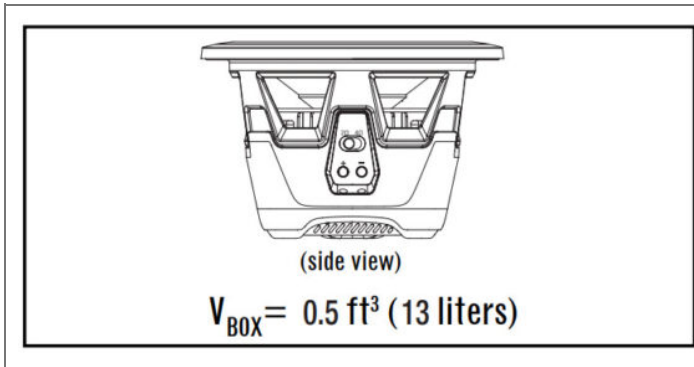

**SEALED-BOX VOLUME (INCLUDES DRIVER DISPLACEMENT)**

**VENTED-BOX VOLUME (INCLUDES DRIVER/PORT DISPLACEMENTS)**

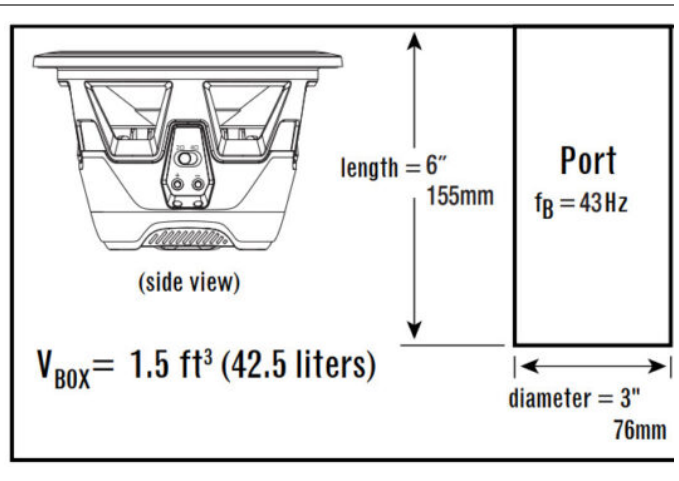
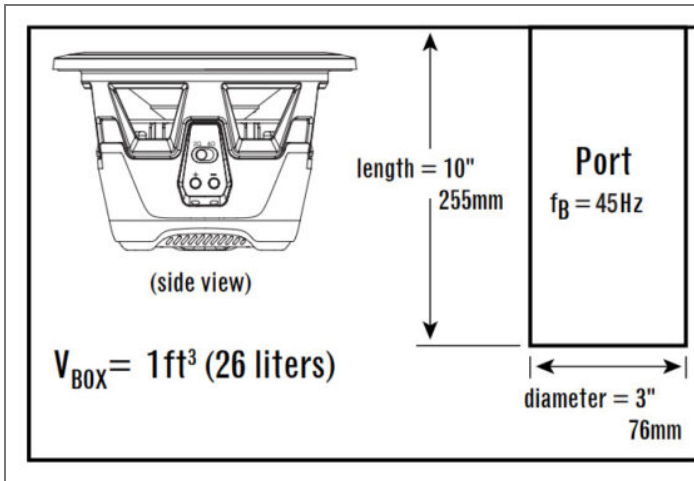

**SPECIFICATIONS**

DIAMETER:	8" (200MM)
SENSITIVITY (2.83V @ 1M):	89dB
POWER HANDLING:	400W RMS (1600W PEAK)
FREQUENCY RESPONSE:	34Hz ~ 200Hz
NOMINAL IMPEDANCE:	2OR 4 OHMS
VOICE-COIL DIAMETER:	2" (51MM)
DIMENSIONS:	

DIAMETER:	10" (250MM)
SENSITIVITY (2.83V @ 1M):	90dB
POWER HANDLING:	450W RMS (1800W PEAK)
FREQUENCY RESPONSE:	30Hz ~ 175Hz
OMINAL IMPEDANCE:	2OR 4 OHMS
VOICE-COIL DIAMETER:	2" (51MM)
DIMENSIONS:	

DIAMETER:	12" (300MM)
SENSITIVITY (2.83V @ 1M):	91dB
POWER HANDLING:	500W RMS (2000W PEAK)
FREQUENCY RESPONSE:	25Hz ~ 175Hz
OMINAL IMPEDANCE:	2OR 4 OHMS
VOICE-COIL DIAMETER:	2" (51MM)
DIMENSIONS:	



HARMAN International Industries, Incorporated  
8500 Balboa Boulevard, Northridge,  
CA 91329 USA  
[www.jbl.com](http://www.jbl.com)

© 2020 HARMAN International Industries, Incorporated.

All rights reserved. JBL is a trademark of HARMAN International Industries, Incorporated, registered in the United States and/or other countries.

Features, specifications, and appearance are subject to change without notice.

## Documents / Resources

[JBL STADIUM 122SSI 12 Inch \(300mm\) High-Performance Car Audio Subwoofer](#) [pdf] Owner's Manual

STADIUM 122SSI, STADIUM 102SSI, STADIUM 82SSI, 12 Inch 300mm High-Performance Car Audio Subwoofer

## References

-  [Official JBL Store - Speakers, Headphones, and More!](#)

Manuals+